

# Powerful and Flexible

The Multifunctional SIMOCODE pro Motor Management System

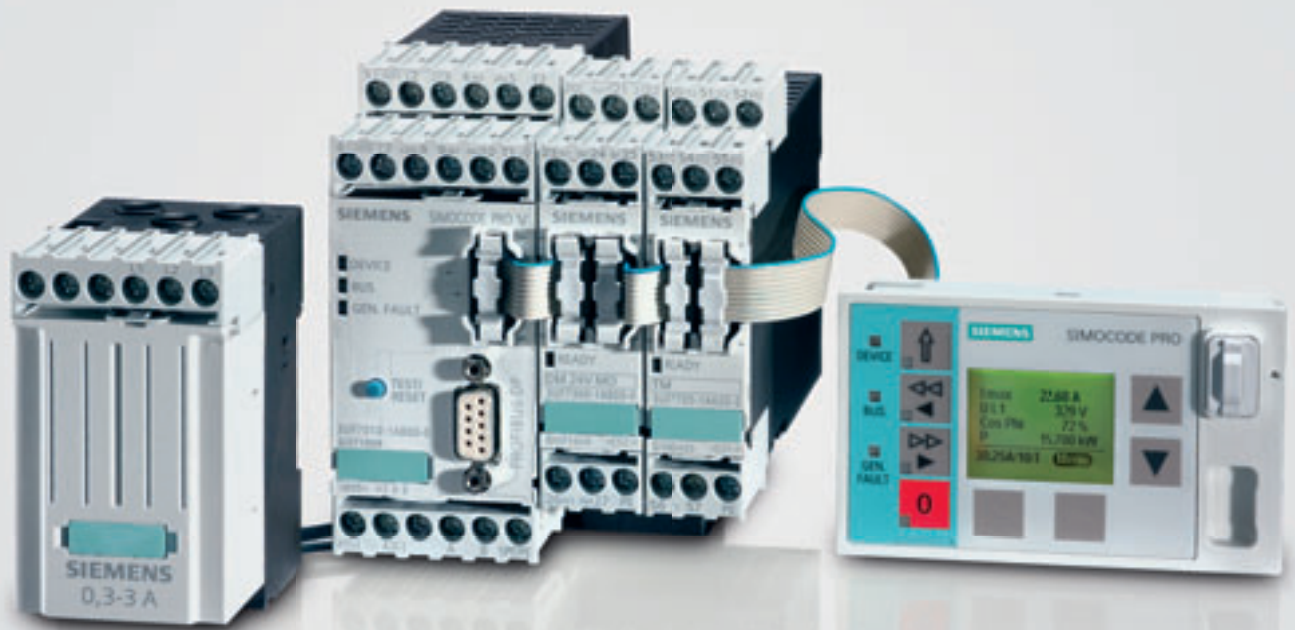

# SIRIUS

Answers for industry.

**SIEMENS**

The next generation:

## SIMOCODE pro takes off.

In many automated processes, plant downtimes have proven themselves to be extremely costly. Costs that can be relatively simply reduced. When the correct technology is applied, faults can either be prevented or when a fault does occur, it can be quickly resolved.

For more than 20 years, SIMOCODE has been perfectly mastering these tasks in many low-voltage power distribution boards worldwide. New market requirements such as the increased application of power management systems or state-based motor monitoring have led to the development of the market's leading motor management system: SIMOCODE pro.

### **More powerful, simpler and more flexible: SIMOCODE pro – the motor management system**

SIMOCODE pro is the flexible and modular motor management system for low-voltage motors that can be simply and directly connected to higher-level automation systems via PROFIBUS DP. From the functionality perspective it covers all of the requirements between the motor feeder and automation system. Further, it combines in just one compact system, all of the necessary protection, monitoring and control functions for every motor feeder. This therefore increases the process control quality and at the same

time reduces the costs – from planning through installation up to operation or service of a plant or system. With a clear focus on current and future requirements, the next generation of the motor management system by Siemens offers comprehensive onboard features:

- Multifunctional, electronic full motor protection, independent of the automation system
- Integrated control functions
- Detailed operating, service and diagnostics data
- Open communications via PROFIBUS DP – the standard of fieldbus systems



#### SIMOCODE pro – Highlights

- Overload protection for motor currents up to 820 A
- Integrated thermistor motor protection
- Integrated earth fault monitoring
- Temperature detection (e.g. Pt100/Pt1000/KTY/NTC)
- Voltage detection up to 690 V
- Power and COS phi/Power Factor
- Analog inputs and outputs
- Communications via PROFIBUS DP up to 12 Mbit/sec
- Standardized and unified, seamless integration
- Graphical parameterizing interface
- Measuring curves can be recorded/traced
- Device internal error memory/error history
- Just 45 mm wide
- Removable current transformer
- Global approvals (e.g.: ATEX, UL/CSA, CCC)
- And a lot more!

Advantages in all areas:

## SIMOCODE pro connects.

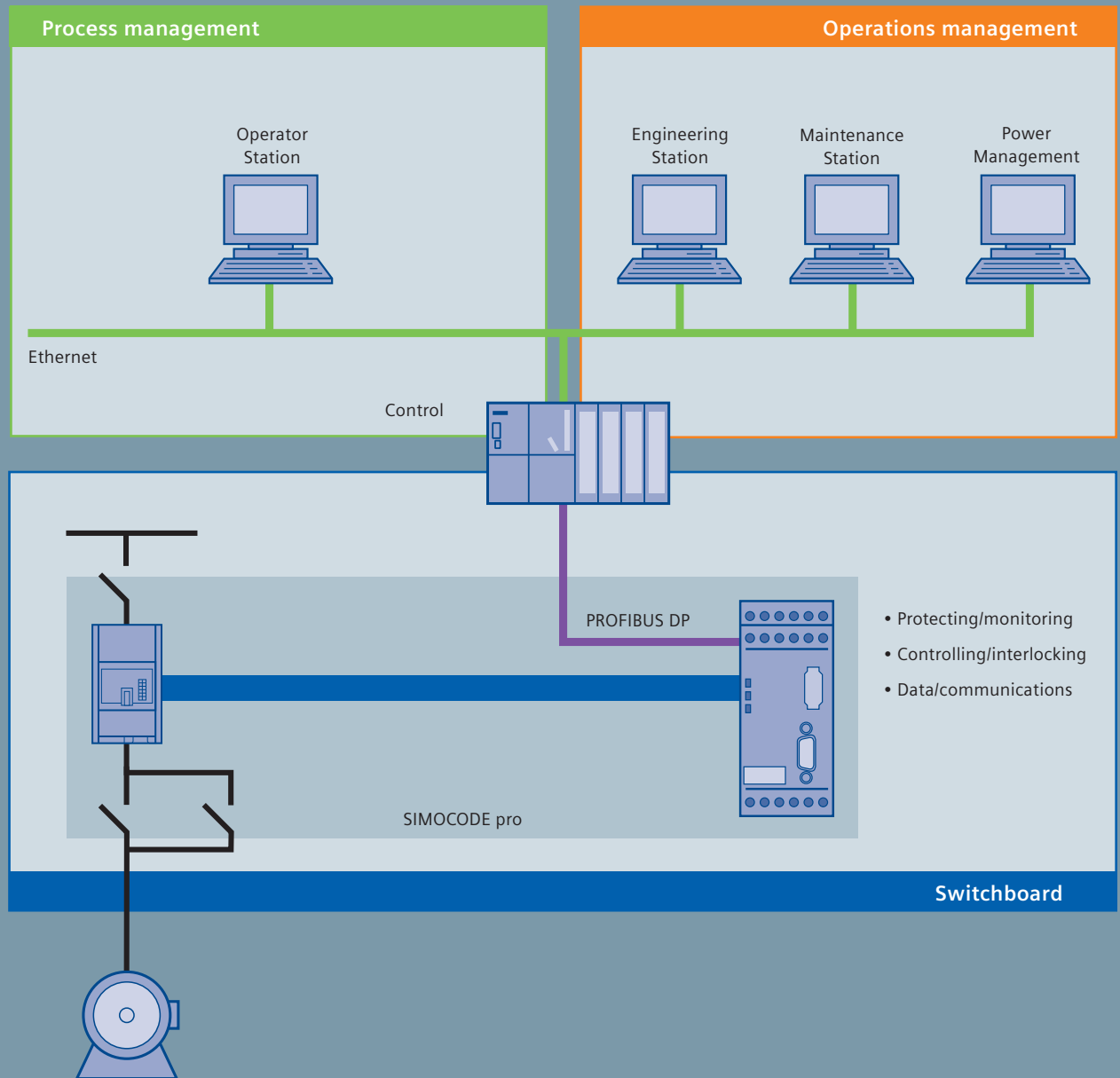

SIMOCODE pro combines all of the functions required for your motor feeder and connects this to higher-level systems via PROFIBUS DP.

## Advantages in all areas

### General:

- Improved system availability
- Fault prevention using monitoring of the motor state
- Faster troubleshooting – faults are resolved using detailed diagnostics data
- Autonomous functions guarantee the availability of the motor feeder also when communications or supervisory control systems fail

### Process management:

- Higher process transparency and higher information density at the supervisory control level than for conventional solutions
- All of the process quantities are available
- Unified and seamless integration (Totally Integrated Automation)
- Standardized motor blocks ease integration in the control system and simplify handling

### Operations management:

- Reduced maintenance and service costs thanks to the integrated status monitoring
- Service and maintenance personnel are supported by an extensive range of service and diagnostics data
- Faults can be more easily reconstructed as measuring curves are recorded and faults logged
- Power-related measured quantities are detected – allowing integration into higher-level power management systems – saving energy costs (Totally Integrated Power)

### Switchboard:

- Flexible and space-saving motor feeders thanks to the small dimensions and modular design
- Integrated PROFIBUS interface makes motor feeders communication-capable
- More functionality in a smaller space when compared to conventional solutions
- Lower wiring costs as the control circuit hardware is replaced by integrated control functions
- Graphic parameterization speeds up commissioning and simplifies plant documentation

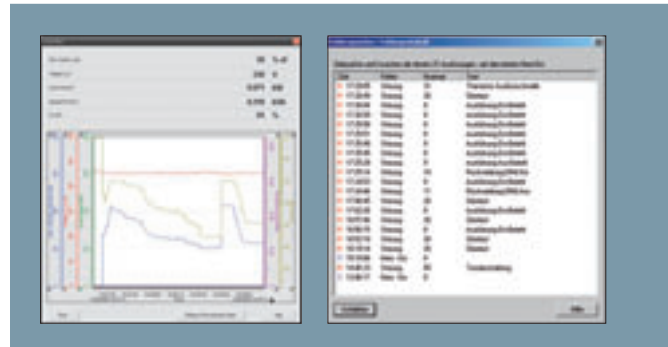
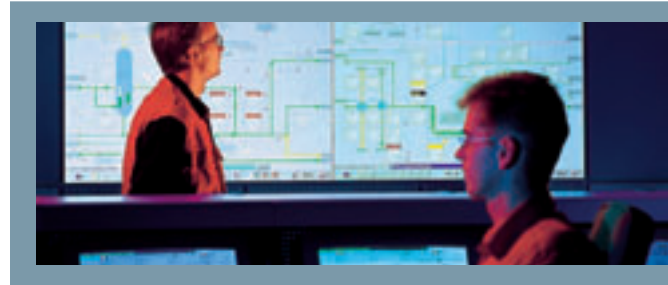

Functionality as it is required:

## SIMOCODE pro is flexible.



SIMOCODE pro C



SIMOCODE pro V

We can offer you two device series that are functionally harmonized with one another so that you can enjoy the benefits of SIMOCODE pro in all areas of the process industry and power generation:

### **SIMOCODE pro C**

The compact motor management system for direct and reversing starters: Presently the most cost-effective, communication-capable motor management system of its class. This makes SIMOCODE pro C the optimum solution – especially when changing over from a conventional to a communication-capable motor feeder.

### **SIMOCODE pro V**

The variable motor management system: It offers an even higher functional scope. Not only this, it can be expanded by precisely those functions that you require in your motor feeder. Up to five optional expansion modules can be connected.

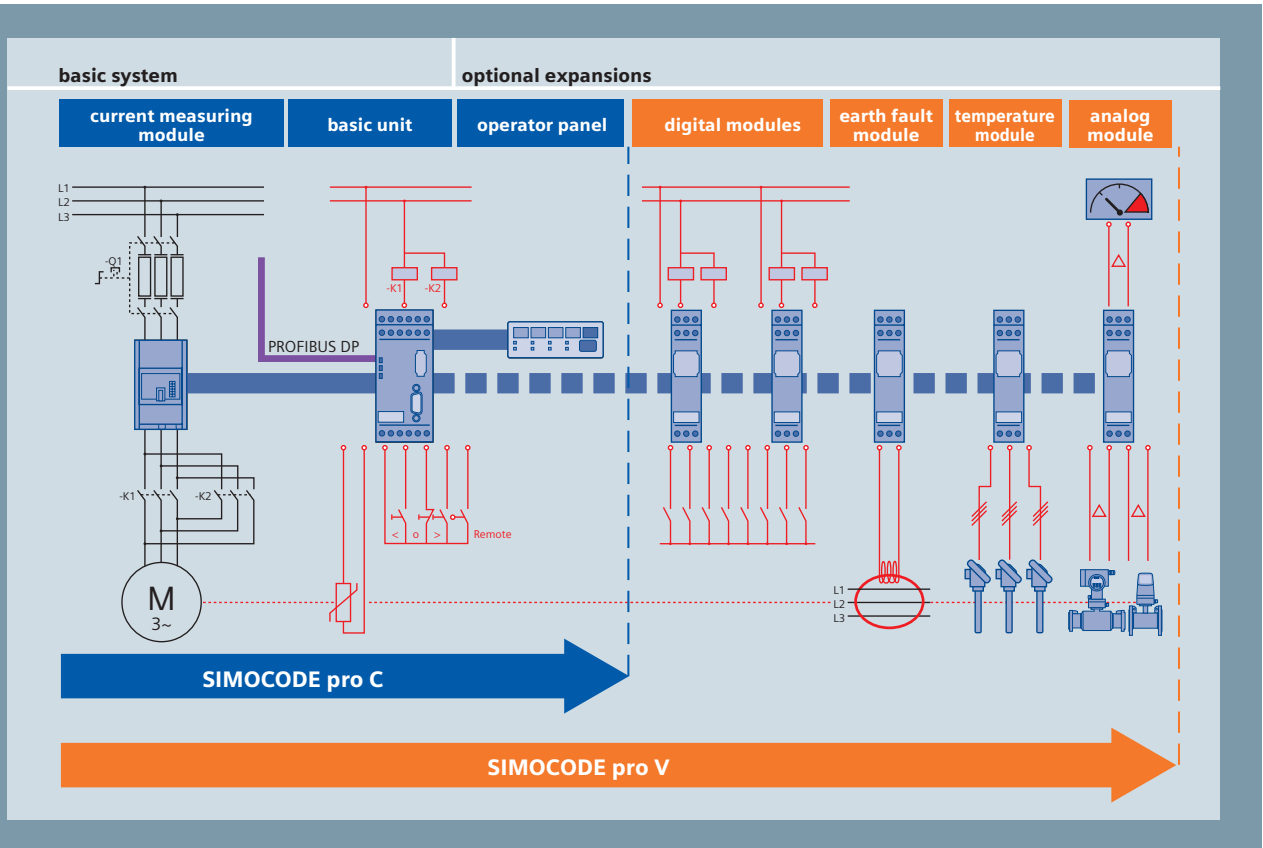

Supplementary functions as required – SIMOCODE pro V expansion modules

**Clever solution:****Mixed operation in one plant**

Depending on the functions required, SIMOCODE pro C and SIMOCODE pro V can be used together without any additional costs. This means that you remain flexible and can save money – quite a lot of money.

**Straightforward integration:****Integrated PROFIBUS DP interface**

SIMOCODE pro has an integrated PROFIBUS DP interface which means that the motor feeder can be integrated as standard into every PROFIBUS DP-capable automation system.

SIMOCODE pro supports among other things:

- Communications with up to three PROFIBUS DP masters
- Cyclic services (DPV0) and acyclic services (DPV1)
- Time synchronization via PROFIBUS\*
- Time stamping with high temporal accuracy\*)

**Guaranteed functionality:****Independently executed protection and control functions**

One of the most outstanding features of SIMOCODE pro is the fact that all of the protection and control functions can be independently executed. This means that even if the bus or automation system fails, the full functionality is kept. And, it is guaranteed that the motor feeder is protected – i.e. the motor feeder remains available. A defined behavior in fault cases can be adjusted.

\* for SIMOCODE pro V

Versatility par excellence:

# SIMOCODE pro is extremely versatile.

Width 45 mm	Width 55 mm	Width 120 mm	Width 145 mm	
				Current measuring modules
				Current/voltage measuring modules
0.3–3 A; 2.4–25 A	10–100 A	20–200 A	63–630 A	
straight-through transformer				
		busbar connection		

The matching intermediate 3UF18 current transformers for the current measuring or current/voltage measuring modules are available to measure and monitor motor currents of up to 820 A.

There is a wide range of modules at your disposal so that SIMOCODE pro can provide you with what you require in the field coupled with the most flexible device functionality possible. Additional interesting functions will be added. Below is an overview of the wide range of versions that you can expect now and in the future.

**One system for all motor feeders:  
Measuring currents up to 820 A**  
SIMOCODE pro monitors motors with rated motor currents up to 820 A. Various current measuring modules are available. The modular design and the integrated, seamless system allow a significantly simpler and flexible integration of the motor feeder.

**By the way:  
Voltage, power and cos-phi/power factor**  
Instead of current measuring modules, for SIMOCODE pro V you can optionally use current/voltage measuring modules. This means that in addition to the motor current, you can also measure voltages up to 690 V and monitor power-related measured quantities.



Operator panel with display for SIMOCODE pro V



Expansion module (here: digital module)

### Easier handling:

#### The operator panel

The operator panel is used to control the motor feeder. It is integrated in a control cabinet door and features IP54 degree of protection. Thus, SIMOCODE pro or the feeder can be directly operated from the control cabinet. The system interface integrated in the operator panel at the front serves convenient PC/PG-based parameterization and diagnostics directly on the control cabinet door. To be able to read measuring values, operational and diagnostics data directly from the control cabinet, the operator panel for SIMOCODE pro V is optionally available with a display.

### Higher range of versions:

#### Expansion modules for SIMOCODE pro V

SIMOCODE pro V not only has even more protection, control and monitoring functions than SIMOCODE pro C, but thanks to the expansion modules can be expanded as required.

#### Digital modules\*

The type and number of digital input and relay outputs of SIMOCODE pro V can be increased step-by-step using digital modules.

This means that you can:

- Input or output additional process signals and implement additional functions
- Externally supplied digital inputs can be retrofitted (24 V DC or 110–240 V AC/DC)
- Bistable relay outputs can be added – the switching status of the relay outputs is kept even after the power supply voltage fails

#### Earth fault module\*

Using the earth fault module, in addition to the earth fault monitoring function integrated into the basic unit, you can configure an even more precise external earth fault monitoring using a summation current transformer.

#### Temperature module\*

In parallel to the thermistor motor protection, using the temperature module, you can integrate up to 3 analog temperature sensors (e.g. Pt100, Pt1000, KTY, NTC) to your process. This for example facilitates the effortless monitoring of bearing, gear oil and coolant temperature.

#### Analog module\*

Using the analog module, you can expand the SIMOCODE pro V system by analog inputs and outputs (0/4 ... 20 mA). This makes process monitoring, e.g. of filling levels, flow rates, dry running or filter contamination, extremely easy.

\* for SIMOCODE pro V

**Extensive functions:**

# SIMOCODE pro optimizes process control and plant operation.

Whether process management, operations management or switchboards – SIMOCODE pro connects all of the areas through extensive data and functions. It provides you with advantages across the board!

## Protecting & Monitoring

**Extensive protection: multi-functional, electronic full motor protection**

SIMOCODE pro offers an extensive protection of the motor feeder by combining various multi-stage protection and monitoring functions:

**Protection functions:**

- Overload protection (Class 5–40)
- Thermistor motor protection
- Phase failure monitoring
- Unbalance protection
- Stall protection
- Earth fault monitoring
- Current limit monitoring
- Operating hours monitoring
- Motor stop time monitoring
- Number-of-starts monitoring
- And a lot more

**Expanded monitoring functions:**

- Temperature monitoring Pt100/ Pt1000\*
- Voltage monitoring\*
- Power monitoring\*
- Cos-phi/power factor monitoring\*
- Phase sequence detection\*
- Input, output and monitoring of 0/4...20 mA signals\*

**Recording of measured curves\***

## Controlling

**Absolutely flexible: Integrated control functions**

SIMOCODE pro already has many pre-defined motor control functions – including all of the necessary interlocks. Your advantage: You save a whole lot of hardware and wiring and you obtain a motor feeder that is highly standardized regarding its circuit diagrams.

**Control functions:**

- Direct on-line starter
- Reversing starter
- Star-delta starter\*
- Star-delta starter with reversal of rotational direction\*
- Two speeds, motors with separate windings (pole changing) also with reversal of rotational direction\*
- Two speeds, motors with separate Dahlander windings, also with reversal of rotational direction\*
- Solenoid valve actuation\*
- Positioner actuation\*
- Circuit-breaker control
- Soft starter actuation\*
- Soft starter actuation with reversal of rotational direction\*

**Simply adapt: using logic blocks and standard functions**

Protection and control functions can, when required, be flexibly adapted to the requirements of your motor feeder. This is achieved using freely parameterizable logic blocks – such as truth tables, counters and edge evaluation – and using standard functions such as line supply failure monitoring\*, emergency start or external faults. Arithmetic functions additionally facilitate the conversion of measured values into any formats or units.

SIMOCODE pro provides you with all of the data required for process and plant operation. This data is available in the switchboard and, to the same extent, also in the supervisory control system. In addition to the many process quantities, it is especially the service and diagnostics data that support your service and main-

tenance personnel. SIMOCODE pro helps you to identify approaching faults and avoid them using preventive measures. However, if a fault actually occurs, then it can be quickly localized and resolved. This means that downtimes are limited to a minimum or don't even occur in the first place.

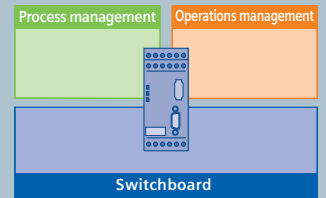

## Communications

### Communications via PROFIBUS DP – extensive data available everywhere

#### Operational data:

- Motor switching state (on, off, counter-clockwise, clockwise, slow, fast)
- Current in phases 1, 2, 3 and maximum current
- Phase voltage 1, 2, 3\*
- Active power\*
- Apparent power\*
- Power factor\*
- Phase unbalance
- Phase sequence\*
- Time to trip
- Temperature rise, motor model
- Remaining cooling time of the motor
- Temperature (e.g. motor temperature)\*
- Actual value, analog signals\*
- And much more

#### Service data:

- Motor operating hours
- Motor stop times
- Number of motor starts
- Number of overload trips
- Internal comments saved in the device
- Device operating hours
- Consumed power\*
- And much more

#### Diagnostics data:

- Numerous detailed early warning and fault messages, also for further processing in the device or in the master control system
- Fault logging within the device with time stamp
- Time stamp for any selectable status, alarm and fault messages\*
- Value of the last tripping current
- Checkback faults (e.g. no current flowing in the main circuit after an On control command)
- And much more

\* for SIMOCODE pro V



## Totally Integrated: Software for integration.

More transparency, more data:  
optimum process control for all process control systems using SIMOCODE pro

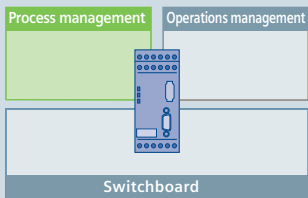

Today, not only sensor data, but also the data of the motor feeder are integrated in the process control system. SIMOCODE pro provides these data to all process control systems via PROFIBUS. This means that SIMOCODE pro increases the degree of transparency of your process and ensures a significantly higher information density in the supervisory control system – but without any additional costs. Based on Totally Integrated Automation, data is integrated seamlessly and in a unified fashion. Standard motor blocks simplify the integration and make handling easier.

### User-friendly integration into the SIMATIC PCS 7 process control system

Using the PCS 7 library, SIMOCODE pro can be simply integrated into the SIMATIC PCS 7 process control system in a user-friendly fashion. The PCS 7 library SIMOCODE pro has for this purpose standard motor blocks and faceplates to operator control and visualization of the motor. In addition, the maintenance-relevant monitoring functions and alarms parameterized in SIMOCODE pro can be directly visualized on a central maintenance station. Furthermore, the power values detected by SIMOCODE pro for every motor feeder offer the optimum basis for superior power management with SIMATIC PCS 7 powerrate.

### Integration into SIMATIC PDM

It goes without saying that SIMOCODE pro is also integrated into SIMATIC PDM (PDM = Process Device Manager) for plant-wide device parameterization and diagnostics. This means that a standard, unified tool is embedded in the process control system for intelligent field devices such as SIMOCODE pro.

SIMATIC PCS 7 Faceplate

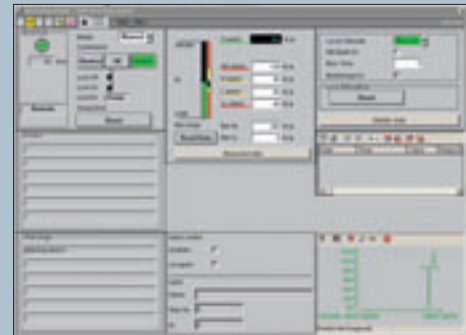

SIMATIC PDM



Parameterization, diagnostics and maintenance-relevant monitoring functions:  
Comfortable operational management with SIMOCODE pro

Increasingly, plant operating companies are expecting information and data for user-friendly operational management using central maintenance and power management systems that are available in addition to the process control. SIMOCODE pro supplies the systems with the necessary data. With SIMOCODE ES, the SIMOCODE pro system provides, among other things, a tool with which all of the data can be displayed and evaluated.

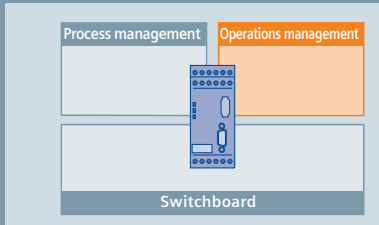

### Diagnostics and maintenance with SIMOCODE ES

With SIMOCODE ES, SIMOCODE pro is comfortably parameterized and diagnosed either centrally via PROFIBUS or directly on the control cabinet. SIMOCODE ES provides important information when maintenance is required or when faults occur by displaying all of the operating, service and diagnostics data of the motor feeder.

This helps to prevent faults, more quickly localize these when a fault occurs and also resolve the problem. The system can be parameterized online – also during operation – thus avoiding unnecessary plant downtimes. Among other things, the following data is displayed in easy to understand dialog boxes:

- Warnings, faults, messages
- Motor operating hours, motor starts
- Error log/error history
- Trends and measuring curves

### Integration into SIMATIC S7 with the object manager for SIMOCODE pro

Our OM SIMOCODE pro object manager is part of SIMOCODE ES and allows SIMOCODE ES to be incorporated in STEP 7. Devices can be configured, unified with S7, and parameterized simply because SIMOCODE ES can be directly executed from STEP 7. This means that SIMOCODE pro is totally integrated into SIMATIC S7.

### Operating and diagnostics data

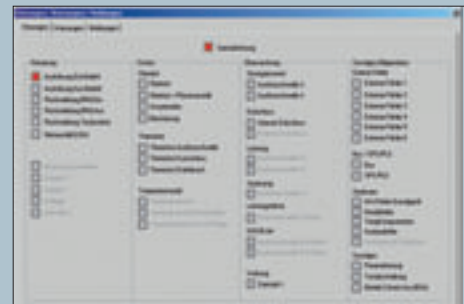

### Evaluating measuring curves

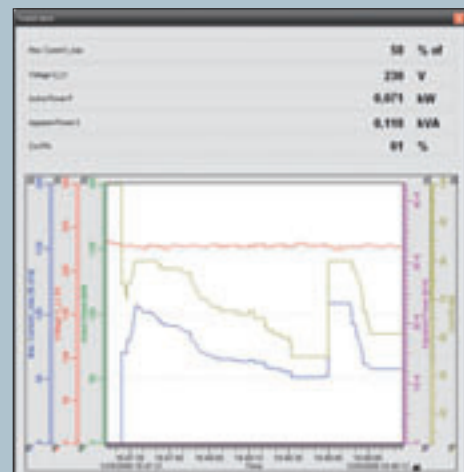

### Maintenance-relevant monitoring functions and data



Easy planning, high degree of engineering security, fast commissioning:  
SIMOCODE pro in the switchboard

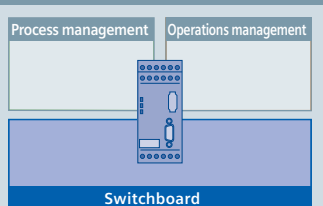

SIMOCODE pro is modular and is extremely compact. This makes it predestined for use in low-voltage switchboards or motor control centers. The extensive functions of SIMOCODE pro can be flexibly adapted to every customized version of a motor feeder. Optional expansion modules provide an additional degree of security when engineering the system. The integrated control functions make additional locking hardware unnecessary. Standardized load feeders such as these decisively simplify planning and mechanical design. For the time-saving commissioning of a power distribution board, also ergonomic tools such as SIMOCODE ES are required.

#### Parameterization and commissioning of the power distribution board with SIMOCODE ES

Control and protective functions as well as wiring of the control circuit are realized through integrated control functions in SIMOCODE pro and parameterized with SIMOCODE ES.

With SIMOCODE ES, SIMOCODE pro offers a user-friendly and clearly structured interface for fast parameterization and commissioning. The integrated print function facilitates the documentation of all parameters in accordance with DIN ISO 7200.

#### Parameterization via drag & drop with the graphical editor

The graphical editor for SIMOCODE ES supports a very ergonomic and user-friendly parameterization via drag & drop. In so doing, the inputs and outputs of function modules can be graphically "soft-wired" and parameters can be set. The configured functions can be described in more detail by inserting comments of any type and the device parameterization can be graphically documented. This again significantly speeds up commissioning and visibly simplifies the documentation.

Predefined control functions



Graphical editor

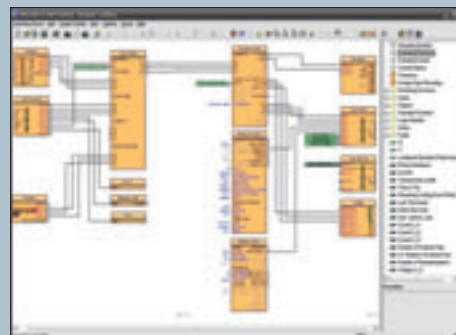

For maximum plant protection:

## SIMOCODE pro with Safety

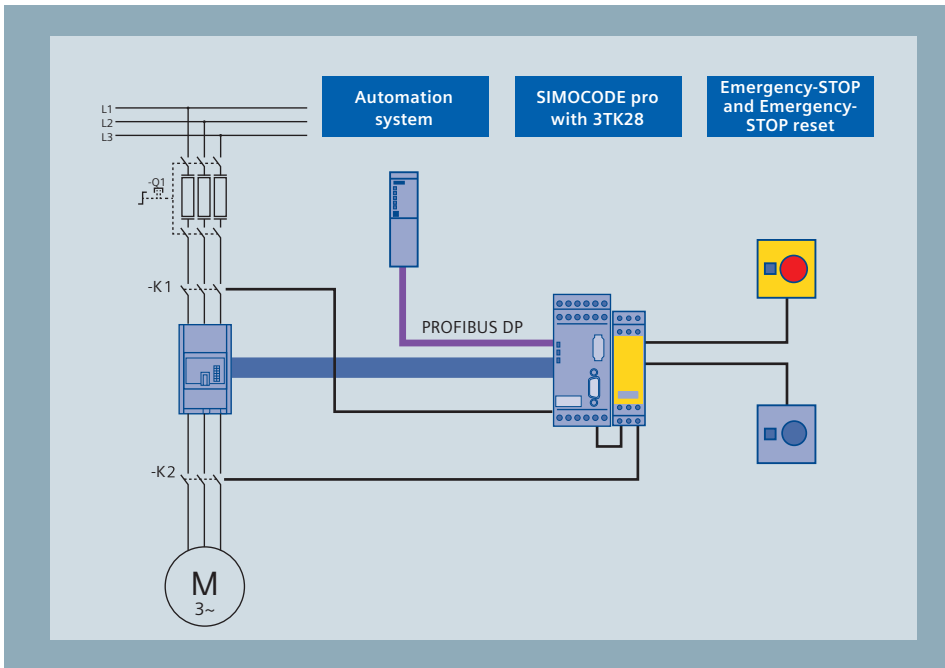

Safe consumer shutdown with SIMOCODE pro



3TK28 safety relay

Also in the field of process automation, the safety-oriented employment of components is gaining in importance. Plants may at any time be subject to situations in which humans or the environment need to be protected by the safety-oriented shutdown of machines, e.g. by a safe motor shutdown. With SIMOCODE pro, you are always on the safe side.

Thanks to the combination of SIMOCODE pro with a 3TK28 safety relay, you profit from the advantages of a flexible, modular motor management system and the safety-oriented shutdown of the respective consumer. All applicable safety standards are complied with.

Humans and machines are extensively protected by the combination of various multi-level protective and monitoring functions in SIMOCODE pro, including the consumer's safety-oriented shutdown.

Via the PROFIBUS interface integrated in SIMOCODE pro, the motor feeder can be integrated in the automation system in a standardized manner. All signal states of the 3TK28 can be signaled to the superior PLC via PROFIBUS. Additional auxiliary contacts for the safety relay and the EMERGENCY-STOP button are abolished. As only a small number of devices is employed and the wiring expenditures are thus reduced, the required space is way smaller than with conventional solutions.

Optimum in use:

## SIMOCODE pro with SIVACON



The SIVACON low-voltage power distribution board: Communication-capable, efficient, highly flexibly and extremely reliable



SIVACON withdrawable units with SIMOCODE pro

With SIMOCODE pro, you have at your fingertips a cost-effective motor management system that is truly fit for the future. It combines long-standing experience with state-of-the-art technology and has been successfully employed in the SIVACON low-voltage power distribution board by Siemens for decades.

In addition to communication-capable soft starters, circuit breakers and AS-Interface modules, a flexible and communication-capable motor management system for low-voltage power distribution boards is offered with SIMOCODE pro. SIMOCODE pro is used in SIVACON – in fixed-mounted, plug-in and withdrawable unit design – and allows load feeders to be configured. Load feeders that have a higher performance and at the same time are extremely compact and able to communicate.

SIVACON – equipped with SIMOCODE pro – allows data transfer with automation systems to be cost-effectively implemented. The standardized, non-proprietary PROFIBUS DP is used as bus system – this allows connections to be established to the widest range of automation devices.

Your project in excellent company:

## SIMOCODE pro put into



"It is extremely advantageous for the entire paper manufacturing process to be able to monitor the behavior of every single drive from the control center."

Helmut Lieberg, Qualified engineer for measuring and control technology at Lang Papier

### Comprehensive diagnostics easily realized

The paper machine 4 of the paper manufacturer Lang situated in the Swabian town of Ettringen daily produces approximately 500 tons of uncoated paper. Within the scope of a plant modernization, the decision-makers at Lang searched for a possibility of integrating this machine in the new SIMATIC PCS 7 process control system in a way which ensures both efficiency and future profitability. SIMOCODE pro meets these requirements best. 130 electrical drives in the area of

raw material processing are now controlled by the motor management system and connected to the control system via PROFIBUS DP. This solution brings significant advantages for the paper manufacturing process. All motor feeders are not only actuated and protected but also reliably integrated into a comprehensive diagnostic concept. The behavior of every single drive can be permanently monitored – virtually in real time – from the control center.

#### All advantages at a glance

- Easy, cost- and space-saving realization of a comprehensive diagnostic concept
- High bus quality and transfer speed
- More precise and rapid fault localization and rectification thanks to detailed diagnostics
- Enhanced flexibility for plant expansions and device replacements
- Increased productivity



"We can now work autonomously and are independent of the plant manufacturer."

Karl Weber, Technical operations manager for the Hofmockel plant manufacturer

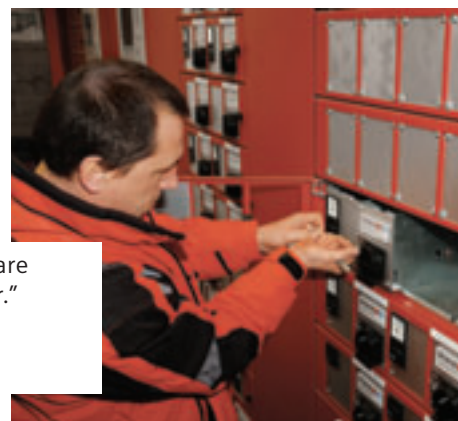

## A clear thing: SIMOCODE pro facilitates standardized sewage processes

The Fürth sewage treatment plant disposes of the wastewater of approx. 265,000 households. To assure safe sewage processes also for the future, the switchboard was modernized and the sludge drainage plant was retrofitted with two new machines. The objective: maximum flexibility, safety and efficiency. For the operator, the suitable solution became clear quite fast: SIMOCODE pro V. The convincing factors were the withdrawable unit technology, the high degree of standardization, the individual parameterization as well as the functional diversity way

beyond current measuring. The flexible modular motor management system SIMOCODE pro V now controls and protects all drives connected to the switchboard and connects them to PROFIBUS DP. Via notebook, the staff can check the state of the drives. Faults are recorded. Any changes in the process sequence can be localized and safety routines can be activated via the devices' parameterization. The result: the sewage treatment plant benefits from a low-wear, efficient and almost autonomous operation.

### Advantages at a glance

- Space-saving device employment with maximum performance and communication capability
- Easy installation and maintenance
- Uncomplicated device replacement
- High standardization degree reduces control and maintenance inspections
- Flexible plant extensions



“Like athletics, we have to consistently use the best equipment to be in top shape during the competition.”

Günter Leinfelder, senior electrician at Südzucker AG



## Targeted motor management prevents process faults

The time between September and December is the high season for sugar. Particularly during these four months, it is vital for sugar producers to handle 24-hour shifts without interruptions. Against this background, Südzucker AG, which is situated in the Swabian town of Rain am Lech, opted for a modernization of diverse plant sections. The core of these modernization measures was the SIMOCODE pro motor management system, which allows for a precise control

and monitoring of the process air. The functionality of all motors can now be monitored at any time – either from the control center or directly on site. With SIMOCODE pro even gradients can be recorded in the devices. This newly gained transparency helps to consistently prevent faults. Furthermore, service works can be carried out efficiently thanks to the easy device replacement, which takes less than 30 seconds with the memory module.

### The solution in detail

- Flexible application even under confined space conditions – thanks to compact dimensions and the separate installation of basic unit and current measuring module
- Optimized servicing as a result of reduced response times and the pluggable memory module, which reads out and records all parameters
- Maximized plant availability – thanks to the possibility of processing and monitoring performance-specific parameters in the device by means of current/voltage measuring modules up to 690 V
- Load monitoring by calculating the active power and the power factor



"Thanks to the numerous additional functions and diagnostic options of SIMOCODE pro, we have clearly out-paced our competitors."

Sandeep Shah, head of the "Technology" division

## A clean solution: SIMOCODE pro for reliable boiler cleaning

The Atlanta-based Clyde Bergemann Inc. is a well-known OEM supplier of state-of-the-art boiler cleaning systems. To be able to offer customers efficient and future-proof solutions for the modernization of their boiler systems, the process engineers searched for a flexible system meeting the following requirements: A modern motor management capable of reliable maintaining a high boiler performance and assuring the continuous removal of soot deposits. A solution without a permanently wired control technology. A system facilitating the basic opera-

tion of the sootblowers independently of the PLC. SIMOCODE pro perfectly satisfied these criteria. With its distributed design, the system features many useful additional functions which considerably ease the engineers' work and reduce costs. As a flexible and modular system, SIMOCODE pro can be easily connected to PROFIBUS, offers a standardized interface and provides detailed operational, service and diagnostics data. It can be easily parameterized and guarantees a reliable cleaning operation even under harsh ambient conditions.

### All advantages at a glance

- Easy installation and maintenance
- Cost savings over the entire service life of the sootblowers
- Time savings thanks to easy parameterization in standardized circuit diagram and hardware configuration
- Increased functional variety thanks to expansion modules
- Manual operation of the sootblowers in fault cases by means of local on-site control
- Active plant monitoring thanks to detailed diagnostics
- Precise, fast fault localization and rectification



"From our point of view, the SIMOCODE pro motor management system is the only real diagnostic solution as it immediately detects pump and fan maloperation. It is exactly the motor management system we have been looking for."

Herbert Eger, senior electrician  
at the Industrial Engineering division at Paulaner

### For a constantly high beer quality: SIMOCODE pro convinces with functional variety

The Paulaner brewery in Munich produces approximately 2.5 mio hectoliters of beer per year. 24 hours a day – seven days a week. To be able to maintain this production output and make the plant fit for the future, the decision-makers decided in favor of the modularly expandable SIMOCODE pro V system when modernizing the control technology in the filtration system. Particularly the high functional variety of SIMOCODE pro getting far beyond mere current measuring convinced the heads of the Industrial

Engineering division at Paulaner. Thanks to the increased number of signal connections realized with connection of additional digital modules, all filtration and cooling process steps can now be centrally monitored and controlled. Process data are directly transferred to the control center. The high plant transparency assures a precise detection and fast rectification of faults as well as the configuration of standardized diagnostic routines.

#### All advantages at a glance

- Space-saving and flexible application
- Easy device replacement
- More precise and rapid fault localization and rectification thanks to detailed diagnostics
- Unified basis for the configuration of standardized diagnostic routines
- Higher plant availability as a result of the increased control system transparency

## Modules and accessories:

## SIMOCODE pro – a system overview

## Basic unit, SIMOCODE pro C



- Description:** Basis component of SIMOCODE pro C, PROFIBUS DP interface, 12 Mbps  
4 inputs / 3 monostable relay outputs, thermistor connection
- Range:** Rated control supply voltage:  
 • 24 V DC                      • 110...240 V AC/DC

## Basic unit, SIMOCODE pro V



- Description:** Basis component of SIMOCODE pro V, PROFIBUS DP interface, 12 Mbps  
4 inputs / 3 monostable relay outputs, thermistor connection, can be functionally expanded using expansion modules
- Range:** Rated control supply voltage:  
 • 24 V DC                      • 110...240 V AC/DC

## Current measuring modules and current/voltage measuring modules\*



- Description:** The motor current in the main circuit is measured separately from the basic unit using a measuring unit. Current/voltage measuring modules also measure voltages up to 690 V in the main circuit.
- Range:** Straight-through current transformer for rated motor currents:  
 • 0.3...3 A                      • 2.4...25 A                      • 10...100 A                      • 20...200 A
- Current transformer with busbar connections for rated motor currents:  
 • 20...200 A                      • 63...630 A
- The matching 3UF18 intermediate current transformers are available to measure and monitor motor currents up to 820 A.

## Operator panel



- Description:** For SIMOCODE pro operation at the control cabinet door with up to 10 LEDs for status display and up to 5 pushbuttons. The SIMOCODE pro V series is optionally available with display.

## Expansion modules\*

**Digital modules**

**Description:** To expand a basic unit by additional digital I/Os; a maximum of 2 digital modules can be connected per basic unit.

- Range:** Relay outputs:                      Input voltage:  
 • Monostable                      • 24 V DC  
 • Bistable                              • 110 ... 240 V AC/DC

**Earth-fault module**









**Description:** To expand the basic unit by one input for the external earth fault detection with a summation current transformer, a maximum of 1 earth fault module can be connected per basic unit.

**Temperature module**

**Description:** For expansion of the basic device by inputs for up to 3 temperature sensors (Pt100, Pt1000, KTY, NTC), a maximum of one temperature module can be connected per basic unit.

**Analog module**

**Description:** To expand the basic unit with two passive analog inputs and one output (0/4...20 mA), maximally one analog module can be connected per basic unit.

<b>Decoupling module</b>	
	<b>Description:</b> For current/voltage measuring modules for the detection of voltage in non-grounded mains
<b>Memory module</b>	
	<b>Description:</b> Supports the back-up of a system's complete parameterization and its transfer to a new system, e.g. for device replacement, without additional tools or detailed device knowledge
<b>Addressing plug</b>	
	<b>Description:</b> To assign a PROFIBUS address without PC/PG at a basic unit by plugging into the system interface
<b>Door adapter</b>	
	<b>Description:</b> To feed out the system interface, e.g. from a control cabinet; this makes the system interface more easily accessible when parameterizing or troubleshooting using a PC/PG
<b>Connection cable</b>	
	<b>Description:</b> To connect the basic unit, current measuring or current/voltage measuring module, operator panel or expansion modules <b>Range:</b> In various lengths
<b>PC cable</b>	
	<b>Description:</b> For serial PC / programming device communication with SIMOCODE pro via the system interface <b>Range:</b> Additional optional adapter for USB interface
<b>SIMOCODE ES</b>	
	<b>Description:</b> Parameterization and service software for SIMOCODE pro, executable under Windows 2000/XP/Vista <b>Range:</b> Versions: <ul style="list-style-type: none"> <li>• SIMOCODE ES Basic for parameterization / diagnostics via system interface on the device</li> <li>• SIMOCODE ES Standard for parameterization / diagnostics via system interface on the device with integrated graphical editor</li> <li>• SIMOCODE ES Premium for parameterization / diagnostics via PROFIBUS or system interface on the device with integrated graphical editor</li> </ul>
<b>PCS 7 function block library</b>	
	<b>Description:</b> To integrate SIMOCODE pro into the PCS 7 process control system <b>Range:</b> Various license models and PCS 7 versions

# Service and Support

Information

Planning

Ordering

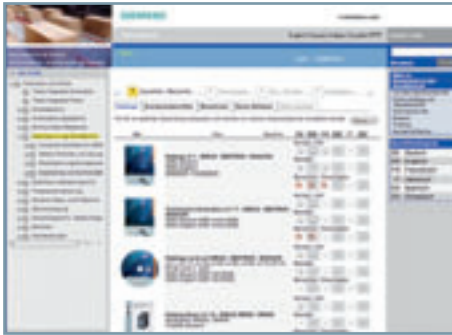

## Easy download of catalogs and information material

The latest catalogs, customer magazines, brochures, demo software and special bargain packages are available for ordering or download from our Information and Download Center:  
[www.siemens.com/lowvoltage/catalogs](http://www.siemens.com/lowvoltage/catalogs)



## Newsletter

Always up to date: Our regular newsletter provides you with topical information on our industrial controls and power distribution products. Simply register at:  
[www.siemens.com/lowvoltage/newsletter](http://www.siemens.com/lowvoltage/newsletter)



## Configurators for ease of handling

Our configurator selection is available at:  
[www.siemens.com/lowvoltage/configurators](http://www.siemens.com/lowvoltage/configurators)



## Online support

Reports and technical data sheets on our products can be found at:  
[www.siemens.com/lowvoltage/support](http://www.siemens.com/lowvoltage/support)



## E-business

24/7-access to a comprehensive information and ordering platform for products and systems of the low-voltage controls and distribution portfolio? Comprehensive information on our complete portfolio? Product selection, order tracking, service, support and training information? All this can be conveniently found at our Mall at:  
[www.siemens.com/lowvoltage/mall](http://www.siemens.com/lowvoltage/mall)

Commissioning / operation

Service

Training



### Online support

Detailed technical information on our products and systems of the low-voltage controls and distribution portfolio, product support and further services and support based on helpful support tools can be found at:

[www.siemens.com/lowvoltage/support](http://www.siemens.com/lowvoltage/support)



### Technical Assistance

You are looking for the right product suiting your application? You have technical questions, require spare parts or want to localize a regional expert? Our experienced team of engineers and technicians will be pleased to assist you:

- Personally from Monday to Friday, 8.00 am to 5.00 pm (CET) via telephone support: **+49 911 895-5900**
- Via e-mail: **technical-assistance@siemens.com**
- Via fax: **+49 911 895-5907**

At [www.siemens.com/lowvoltage/technical-assistance](http://www.siemens.com/lowvoltage/technical-assistance), you can also access the Siemens Service & Support Internet platform for Industry Automation and Drive Technologies. Here, you can search the FAQ database for information and solutions matching your task or directly send your questions to our technical consultants via the support request.



### Training

Our training centers at numerous sites worldwide offer individual training programs covering all fields of automation and industrial solutions. Moreover, with the help of our online courses and various learning software, you can acquire new know-how even more time- and cost-efficiently. More information on our comprehensive SITRAIN training program is available on the Internet at [www.siemens.com/sitrain-cd](http://www.siemens.com/sitrain-cd)

- Or contact us personally:
- via information hotline: **+49 1805 25 36 11** or
  - Fax: **+49 1805 23 56 12**

**Ordering by fax +49 911 978-3321 – CD/Z1373**



SIRIUS Industrial Controls

**Newsletter**

Always up to date:  
Our regular newsletter provides you with topical information on all subjects of industrial controls and power distribution. Simply register at [www.siemens.com/lowvoltage/newsletter](http://www.siemens.com/lowvoltage/newsletter)

Please send the selected information to the following address:

\_\_\_\_\_  
Company/Department

\_\_\_\_\_  
Name

\_\_\_\_\_  
Street, Postal Code/City

\_\_\_\_\_  
Telephone/Fax

\_\_\_\_\_  
E-mail

SWITCHING	<input type="checkbox"/> SIRIUS Solid-state switching devices		
STARTING	<input type="checkbox"/> SIRIUS Infeed system	<input type="checkbox"/> SIRIUS Engineering load feeders	<input type="checkbox"/> SIRIUS Compact starter
	<input type="checkbox"/> SIRIUS Soft starter	<input type="checkbox"/> SIMATIC ET 200pro	<input type="checkbox"/> SIRIUS Motor starter
MONITORING AND CONTROLLING	SIRIUS Motor management system SIMOCODE pro	<input type="checkbox"/> SIRIUS Relays	<input type="checkbox"/> SIRIUS Modular safety system
		<input type="checkbox"/> SIRIUS Safety Relays	
DETECTING	<input type="checkbox"/> SIRIUS Position switches		
COMMANDING AND SIGNALING	<input type="checkbox"/> SIRIUS Pushbuttons and indicator lights	<input type="checkbox"/> SIRIUS Signaling columns and integrated signal lamps	<input type="checkbox"/> SIRIUS Cable-operated switches
	<input type="checkbox"/> SIVENT Fans	<input type="checkbox"/> SIDAC Reactors and filters	<input type="checkbox"/> SIDAC and SIVENT Solutions
SUPPLYING	<input type="checkbox"/> Motor Starter ES		
	<input type="checkbox"/> Soft Starter ES		
ENGINEERING	<input type="checkbox"/> SIRIUS Safety Integrated	<input type="checkbox"/> AS-Interface	<input type="checkbox"/> SIRIUS Connection systems
	<input type="checkbox"/> ECOFAST	<input type="checkbox"/> AS-i News	<input type="checkbox"/> SIRIUS Modular system
	<input type="checkbox"/> The Secrets of UL – You have our support		
SIRIUS AND MORE			

Siemens AG  
Industry Sector  
Low-Voltage Controls and Distribution  
P.O. Box 48 48  
90327 NÜRNBERG  
GERMANY

Subject to change without prior notice 04/08  
Order No. E20001-A560-P305-V2-7600  
Dispo 27602  
21/10820 FGSM.52.8.02 WS 04085.0  
Printed in Germany  
© Siemens AG 2008

[www.siemens.com/simocode](http://www.siemens.com/simocode)

The information provided in this brochure contains merely general descriptions or characteristics of performance which in actual case of use do not always apply as described or which may change as a result of further development of the products. An obligation to provide the respective characteristics shall only exist if expressly agreed in the terms of contract.

All product designations may be trademarks or product names of Siemens AG or supplier companies whose use by third parties for their own purposes could violate the rights of the owners.