

# Pressure Measurement

## Transmitters for general requirements

### SITRANS P DS III Technical description

#### Overview

2



SITRANS P DS III pressure transmitters are digital pressure transmitters featuring extensive user-friendliness and high accuracy. The parameterization is performed using control keys or via HART communication, PROFIBUS-PA or FOUNDATION Fieldbus interface.

Extensive functionality enables the pressure transmitter to be precisely adapted to the plant's requirements. Operation is very simple in spite of the numerous setting options.

Transmitters with type of protection "Intrinsic safety" and "Explosion-proof" may be installed within potentially explosive atmospheres (zone 1) or in zone 0. The transmitters are provided with an EC type examination certificate and comply with the corresponding harmonized European standards (ATEX).

The transmitters can be equipped with various designs of remote seals for special applications such as the measurement of highly viscous substances.

Various versions of the DS III pressure transmitters are available for measuring:

- Gauge pressure
- Absolute pressure
- Differential pressure
- Level
- Volume level
- Mass level
- volume flow
- Mass flow

#### Benefits

- High quality and service life
- High reliability even under extreme chemical and mechanical loads
- For aggressive and non-aggressive gases, vapors and liquids
- Extensive diagnosis and simulation functions
- Separate replacement of measuring cell and electronics without recalibration
- Minimum conformity error
- Small long-term drift
- Wetted parts made of high-grade materials (e.g. stainless steel, Hastelloy, gold, Monel, tantalum)

- Infinitely adjustable span from 0.01 bar to 700 bar (0.15 psi to 10153 psi) for DS III with HART interface
- Nominal measuring range from 1 bar to 700 bar (14.5 psi to 10153 psi) for DS III with PROFIBUS PA and FOUNDATION Fieldbus interface
- High measuring accuracy
- Parameterization over control keys and HART communication, PROFIBUS PA communication or FOUNDATION Fieldbus interface.

#### Application

The pressure transmitters of the DS III series, can be used in industrial areas with extreme chemical and mechanical loads. Electromagnetic compatibility in the range 10 kHz to 1 GHz makes the DS III pressure transmitters suitable for locations with high electromagnetic emissions.

Pressure transmitters with type of protection "Intrinsic safety" and "Explosion-proof" may be installed within potentially explosive atmospheres (zone 1) or in zone 0. The pressure transmitters are provided with an EC type examination certificate and comply with the corresponding harmonized European standards (ATEX).

Pressure transmitters with the type of protection "Intrinsic safety" for use in zone 0 may be operated with power supply units of category "ia" and "ib".

The transmitters can be equipped with various designs of remote seals for special applications such as the measurement of highly viscous substances.

The pressure transmitter can be operated locally over 3 control buttons or programmed externally over HART communication or over PROFIBUS PA or FOUNDATION Fieldbus interface.

# Pressure Measurement

## Transmitters for general requirements

SITRANS P DS III  
Technical description

### Pressure transmitter for gauge pressure

Measured variable: Gauge pressure of aggressive and non-aggressive gases, vapors and liquids.

Span (infinitely adjustable)

for DS III HART: 0.01 bar to 700 bar (0.15 psi to 10153 psi)

Nominal measuring range

for DS III PA and FF: 1 bar to 700 bar (14.5 psi to 10153 psi)

### Pressure transmitters for absolute pressure

Measured variable: Absolute pressure of aggressive and non-aggressive gases, vapors and liquids.

Span (infinitely adjustable)

for DS III HART: 8.3 mbar a ... 100 bar a (0.12 ... 1450 psi)

Nominal measuring range

for DS III PA and FF: 250 mbar a ... 100 bar a (3.6 ... 1450 psi)

There are two series:

- Gauge pressure series
- Differential pressure series

### Pressure transmitters for differential pressure and flow

Measured variables:

- Differential pressure
- Small positive or negative pressure
- Flow  $q \sim \sqrt{\Delta p}$  (together with a primary differential pressure device (see Chapter "Flow Meters"))

Span (infinitely adjustable)

for DS III HART: 1 mbar ... 30 bar (0.0145 ... 435 psi)

Nominal measuring range

for DS III PA and FF: 20 mbar ... 30 bar (0.29 ... 435 psi)

### Pressure transmitters for level

Measured variable: Level of aggressive and non-aggressive liquids in open and closed vessels.

Span (infinitely adjustable)

for DS III HART: 25 mbar ... 5 bar (0.363 ... 72.5 psi)

Nominal measuring range

for DS III PA and FF: 250 mbar ... 5 bar (3.63 ... 72.5 psi)

Nominal diameter of the mounting flange

- DN 80 or DN 100
- 3 inch or 4 inch

In the case of level measurements in open containers, the low-pressure connection of the measuring cell remains open (measurement "compared to atmospheric").

In the case of measurements in closed containers, the lower-pressure connection has to be connected to the container in order to compensate the static pressure.

The wetted parts are made from a variety of materials, depending on the degree of corrosion resistance required.

### Design

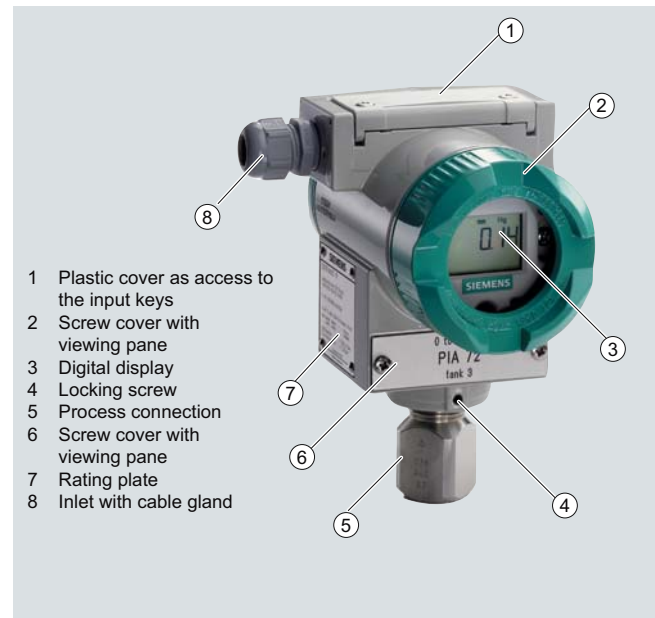

Front view

The transmitter consists of various components depending on the order. The possible versions are listed in the ordering information. The components described below are the same for all transmitters.

The rating plate (7, Figure "Front view") with the Order No. is located on the side of the housing. The specified number together with the ordering information provide details on the optional design details and on the possible measuring range (physical properties of built-in sensor element).

The approval label is located on the opposite side.

The housing is made of die-cast aluminium or stainless steel precision casting. A round cover (6) is screwed on at the front and rear of the housing. The front cover can be fitted with a viewing pane so that the measured values can be read directly on the digital display. The inlet (8) for the electrical connection is located either on the left or right side. The unused opening on the opposite side is sealed by a blanking plug. The protective earth connection is located on the rear of the housing.

The electrical connections for the power supply and screen are accessible by unscrewing the rear cover. The bottom part of the housing contains the measuring cell with process connection (5). The measuring cell is prevented from rotating by a locking screw (4). As the result of this modular design, the measuring cell and the electronics can be replaced separately from each other. The set parameter data are retained.

At the top of the housing is a plastic cover (1), which hides the input keys.

### Example for an attached measuring point label

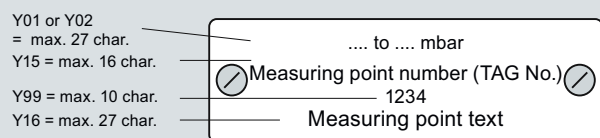

# Pressure Measurement

## Transmitters for general requirements

### SITRANS P DS III

#### Technical description

#### Function

##### Operation of electronics with HART communication

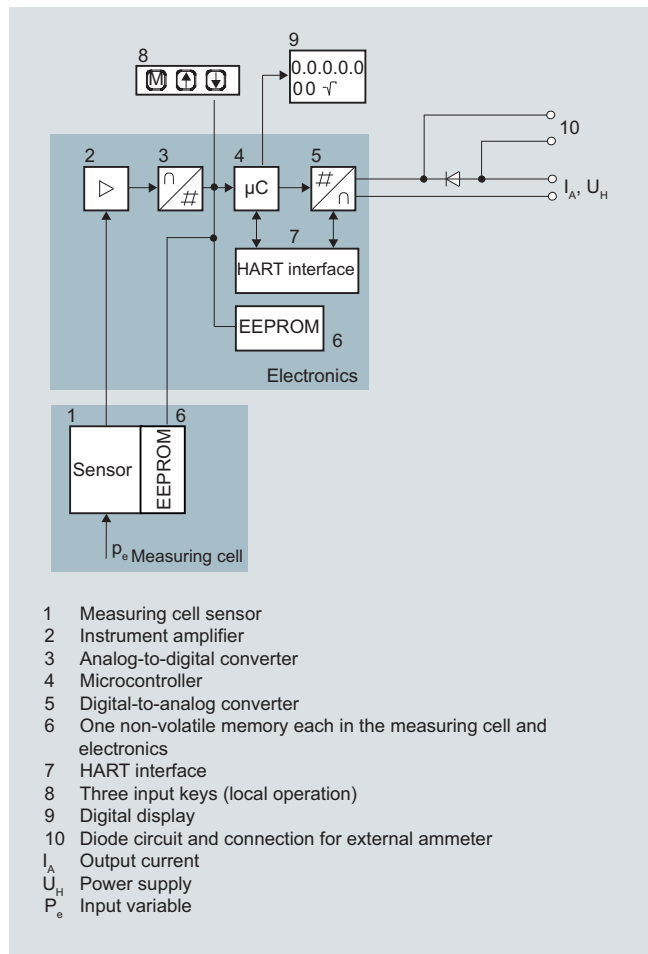

Function diagram of electronics

The bridge output voltage created by the sensor (1, Figure "Function diagram of the electronics") is amplified by the measuring amplifier (2) and digitized in the analog-to-digital converter (3). The digital information is evaluated in a microcontroller, its linearity and temperature response corrected, and converted in a digital-to-analog converter (5) into an output current of 4 to 20 mA.

The diode circuit (10) protects against incorrect polarity.

The data specific to the measuring cell, the electronics data, and the parameter data are stored in the two non-volatile memories (6). The one memory is coupled to the measuring cell, the other to the electronics. As the result of this modular design, the electronics and the measuring cell can be replaced separately from each other.

Using the 3 input keys (8) you can parameterize the pressure transmitter directly at the measuring point. The input buttons can also be used to control the view of the results, the error messages and the operating modes on the digital display (9).

The HART modem (7) permits parameterization using a protocol according to the HART specification.

The pressure transmitters with spans  $\leq 63$  bar measure the input pressure compared to atmosphere, transmitters with spans  $\geq 160$  bar compared to vacuum.

##### Operation of electronics with PROFIBUS PA communication

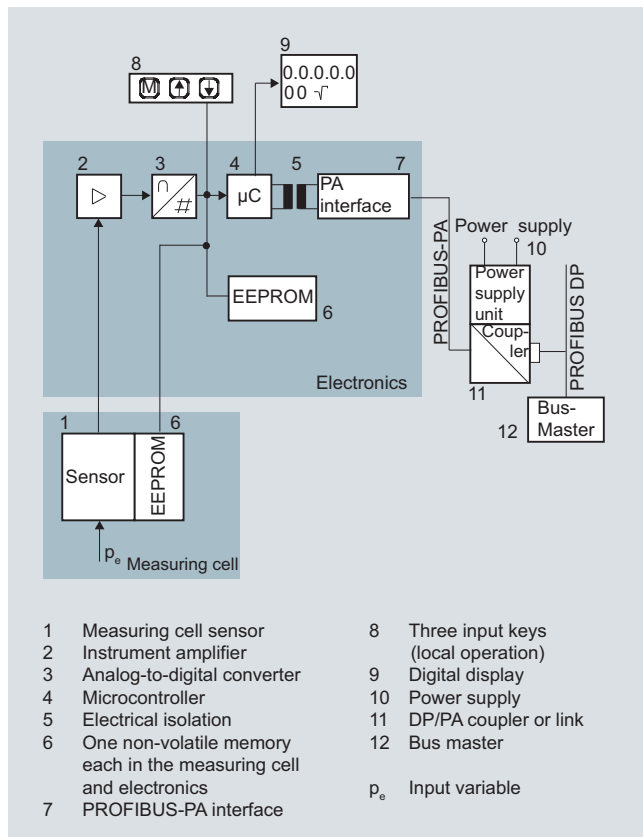

Function diagram of electronics

The bridge output voltage created by the sensor (1, Figure "Function diagram of the electronics") is amplified by the measuring amplifier (2) and digitized in the analog-to-digital converter (3). The digital information is evaluated in the microcontroller, its linearity and temperature response corrected, and provided on the PROFIBUS PA through an electrically isolated PA interface (7).

The data specific to the measuring cell, the electronics data, and the parameter data are stored in the two non-volatile memories (6). The one memory is coupled to the measuring cell, the other to the electronics. As the result of this modular design, the electronics and the measuring cell can be replaced separately from each other.

Using the three input buttons (8) you can parameterize the pressure transmitter directly at the measuring point. The input buttons can also be used to control the view of the results, the error messages and the operating modes on the digital display (9).

The results with status values and diagnostic values are transferred by cyclic data transmission on the PROFIBUS PA. Parameterization data and error messages are transferred by acyclic data transmission. Special software such as SIMATIC PDM is required for this.

# Pressure Measurement

## Transmitters for general requirements

SITRANS P DS III  
Technical description

### Operation of electronics with FOUNDATION Fieldbus communication

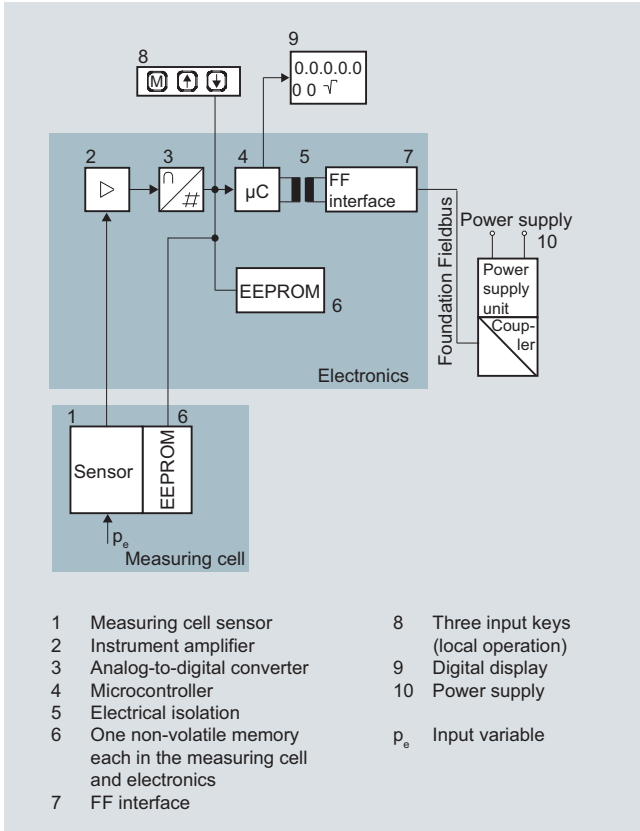

#### Function diagram of electronics

The bridge output voltage created by the sensor (1, Figure "Function diagram of electronics") is amplified by the measuring amplifier (2) and digitized in the analog-to-digital converter (3). The digital information is evaluated in the microcontroller, its linearity and temperature response corrected, and provided on the FOUNDATION Fieldbus through an electrically isolated FOUNDATION Fieldbus interface (7).

The data specific to the measuring cell, the electronics data, and the parameter data are stored in the two non-volatile memories (6). The one memory is coupled to the measuring cell, the other to the electronics. As the result of this modular design, the electronics and the measuring cell can be replaced separately from each other.

Using the three input buttons (8) you can parameterize the pressure transmitter directly at the measuring point. The input buttons can also be used to control the view of the results, the error messages and the operating modes on the digital display (9).

The results with status values and diagnostic values are transferred by cyclic data transmission on the FOUNDATION Fieldbus. Parameterization data and error messages are transferred by acyclic data transmission. Special software such as National Instruments Configurator is required for this.

### Mode of operation of the measuring cells

#### Measuring cell for gauge pressure

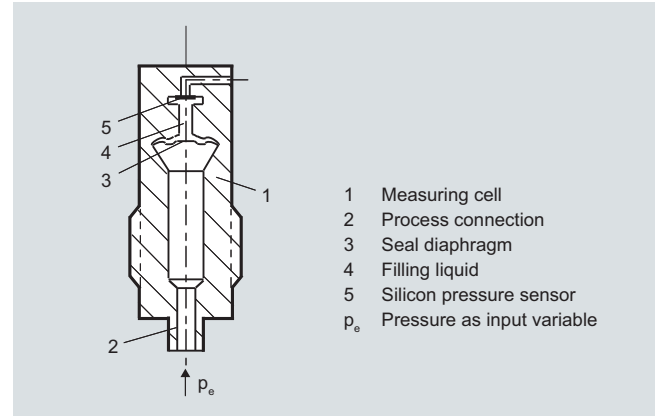

#### Measuring cell for gauge pressure, function diagram

The pressure  $p_e$  is applied through the process connection (2, Figure "Measuring cell for gauge pressure, function diagram") to the measuring cell (1). This pressure is subsequently transmitted further through the seal diaphragm (3) and the filling liquid (4) to the silicon pressure sensor (5) whose measuring diaphragm is then flexed. This changes the resistance of the four piezo-resistors fitted in the diaphragm in a bridge circuit. This change in resistance results in a bridge output voltage proportional to the absolute pressure.

#### Measuring cell for gauge pressure with front-flush diaphragm

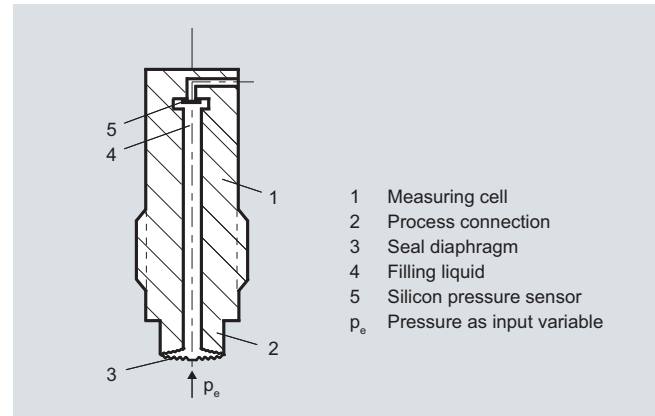

#### Measuring cell for gauge pressure, with front-flush diaphragm for paper industry, function diagram

The pressure  $p_e$  is applied through the process connection (2, Figure "Measuring cell for gauge pressure, with front-flush diaphragm for paper industry, function diagram") to the measuring cell (1). This pressure is subsequently transmitted further through the seal diaphragm (3) and the filling liquid (4) to the silicon pressure sensor (5) whose measuring diaphragm is then flexed. This changes the resistance of the four piezo-resistors fitted in the diaphragm in a bridge circuit. This change in resistance results in a bridge output voltage proportional to the absolute pressure.

# Pressure Measurement

## Transmitters for general requirements

### SITRANS P DS III Technical description

#### Measuring cell for absolute pressure from gauge pressure series

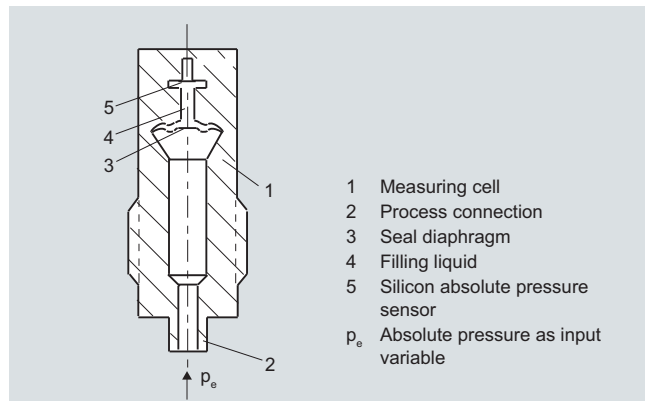

Measuring cell for absolute pressure from the pressure series, function diagram

The absolute pressure  $p_e$  is transmitted through the seal diaphragm (3, Figure "Measuring cell for absolute pressure from pressure series, gauge pressure, function diagram") and the filling liquid (4) to the silicon absolute pressure sensor (5) whose measuring diaphragm is then flexed. This changes the resistance of the four piezo-resistors fitted in the diaphragm in a bridge circuit. This change in resistance results in a bridge output voltage proportional to the absolute pressure.

#### Measuring cell for absolute pressure from differential pressure series

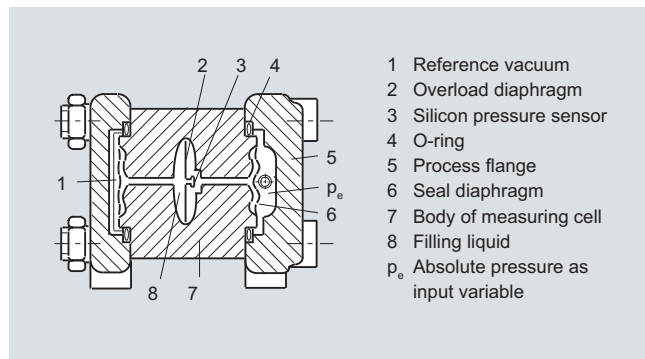

Measuring cell for absolute pressure from differential pressure series, function diagram

The input pressure  $p_e$  is transmitted through the seal diaphragm (6, Figure "Measuring cell for absolute pressure from differential pressure series, function diagram") and the filling liquid (8) to the silicon pressure sensor (3).

The difference in pressure between the input pressure  $p_e$  and the reference vacuum (1) on the low-pressure side of the measuring cell flexes the measuring diaphragm. This changes the resistance of the four piezo-resistors fitted in the diaphragm in a bridge circuit. This change in resistance results in a bridge output voltage proportional to the absolute pressure.

An overload diaphragm is installed to provide protection from overloads. If the measuring limits are exceeded, the overload diaphragm (2) is flexed until the seal diaphragm rests on the body of the measuring cell (7), thus protecting the silicon pressure sensor from overloads.

#### Measuring cell for differential pressure and flow

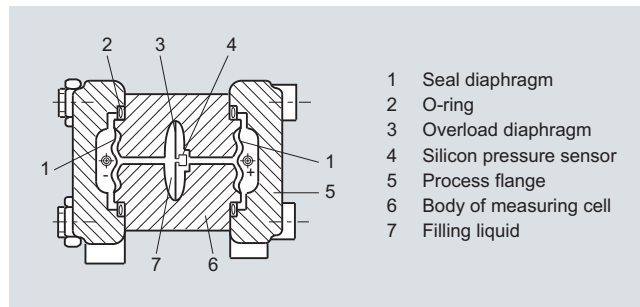

Measuring cell for differential pressure and flow, function diagram

The differential pressure is transmitted through the seal diaphragms (1, Figure "Measuring cell for differential pressure and flow, function diagram") and the filling liquid (7) to the silicon pressure sensor (4).

The measuring diaphragm is flexed by the applied differential pressure. This changes the resistance of the four piezo-resistors fitted in the diaphragm in a bridge circuit. This change in resistance results in a bridge output voltage proportional to the absolute pressure.

An overload diaphragm is installed to provide protection from overloads. If the measuring limits are exceeded, the overload diaphragm (2) is flexed until the seal diaphragm rests on the body of the measuring cell (7), thus protecting the silicon pressure sensor from overloads.

#### Measuring cell for level

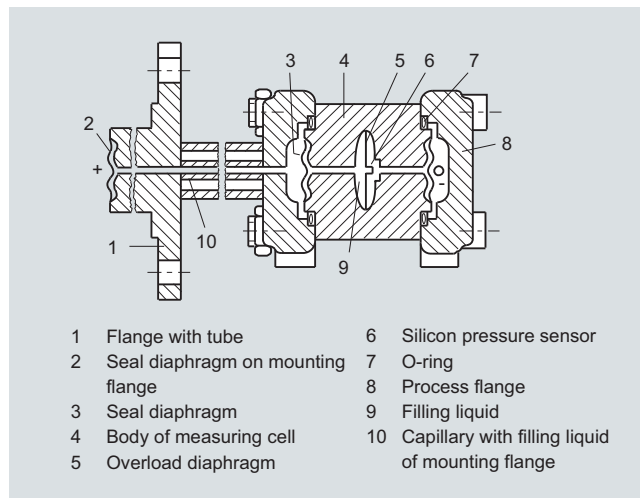

Measuring cell for level, function diagram

The input pressure (hydrostatic pressure) acts hydraulically on the measuring cell through the seal diaphragm on the mounting flange (2, Figure "Measuring cell for level, function diagram"). This differential pressure is subsequently transmitted further through the measuring cell (3) and the filling liquid (9) to the silicon pressure sensor (6) whose measuring diaphragm is then flexed.

This changes the resistance of the four piezo-resistors fitted in the diaphragm in a bridge circuit.

This change in resistance results in a bridge output voltage proportional to the differential pressure.

An overload diaphragm is installed to provide protection from overloads. If the measuring limits are exceeded, the overload diaphragm (2) is flexed until the seal diaphragm rests on the body of the measuring cell (7), thus protecting the silicon pressure sensor from overloads.

# Pressure Measurement

## Transmitters for general requirements

SITRANS P DS III  
Technical description

### Parameterization DS III

Depending on the version, there are a range of options for parameterizing the pressure transmitter and for setting or scanning the parameters.

#### Parameterization using the input buttons (local operation)

With the input buttons you can easily set the most important parameters without any additional equipment.

#### Parameterization using HART communication

Parameterization using HART communication is performed with a HART communicator or a PC.

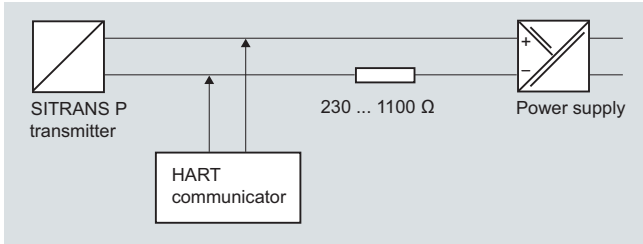

Communication between a HART communicator and a pressure transmitter

When parameterizing with the HART communicator, the connection is made directly to the 2-wire cable.

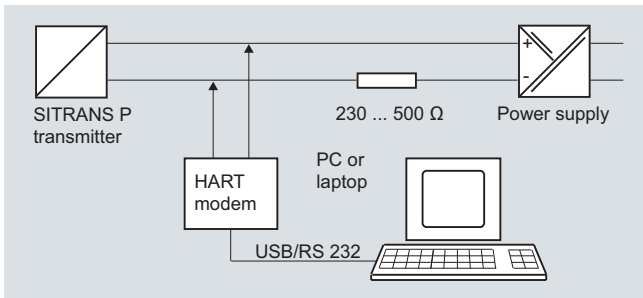

HART communication between a PC communicator and a pressure transmitter

When parameterizing with a PC, the connection is made through a HART modem.

The signals needed for communication in conformity with the HART 5.x or 6.x protocols are superimposed on the output current using the Frequency Shift Keying (FSK) method.

#### Adjustable parameters, DS III HART

Parameters	Input keys (DS III HART)	HART communication
Start of scale	x	x
Full-scale value	x	x
Electrical damping	x	x
Start-of-scale value without application of a pressure ("Blind setting")	x	x
Full-scale value without application of a pressure ("Blind setting")	x	x
Zero adjustment	x	x
current transmitter	x	x
Fault current	x	x
Disabling of buttons, write protection	x	x <sup>1)</sup>
Type of dimension and actual dimension	x	x
Characteristic (linear / square-rooted)	x <sup>2)</sup>	x <sup>2)</sup>
Input of characteristic		x
Freely-programmable LCD		x
Diagnostic functions		x

1) Cancel apart from write protection

2) Only differential pressure

#### Diagnostic functions for DS III HART

- Zero correction display
- Event counter
- Limit transmitter
- Saturation alarm
- Slave pointer
- Simulation functions
- Maintenance timer

#### Available physical units of display for DS III HART

Table style: Technical specifications 2

Physical variable	Physical dimensions
Pressure (setting can also be made in the factory)	Pa, MPa, kPa, bar, mbar, torr, atm, psi, g/cm <sup>2</sup> , kg/cm <sup>2</sup> , inH <sub>2</sub> O, inH <sub>2</sub> O (4 °C), mmH <sub>2</sub> O, ftH <sub>2</sub> O (20 °C), inHg, mmHg
Level (height data)	m, cm, mm, ft, in
Volume	m <sup>3</sup> , dm <sup>3</sup> , hl, yd <sup>3</sup> , ft <sup>3</sup> , in <sup>3</sup> , US gallon, Imp. gallon, bushel, barrel, barrel liquid
Mass	g, kg, t, lb, Ston, Lton, oz
volume flow	m <sup>3</sup> /d, m <sup>3</sup> /h, m <sup>3</sup> /s, l/min, l/s, ft <sup>3</sup> /d, ft <sup>3</sup> /min, ft <sup>3</sup> /s, US gallon/min, US gallon/s
Mass flow	t/d, t/h, t/min, kg/d, kg/h, kg/min, kg/s, g/d, g/h, g/min, g/s, lb/d, lb/h, lb/min, lb/s, LTon/d, LTon/h, STon/d, STon/h, STon/min
Temperature	K, °C, °F, °R
Miscellaneous	%, mA

#### Parameterization through PROFIBUS PA interface

Fully digital communication through PROFIBUS PA, profile 3.0, is particularly user-friendly. The PROFIBUS puts the DS III PA in connection with a process control system, e.g. SIMATIC PSC 7. Communication is possible even in a potentially explosive environment.

For parameterization through PROFIBUS you need suitable software, e.g. SIMATIC PDM (Process Device Manager).

#### Parameterization through FOUNDATION Fieldbus interface

Fully digital communication through FOUNDATION Fieldbus is particularly user-friendly. Through the FOUNDATION Fieldbus the DS III FF is connected to a process control system. Communication is possible even in a potentially explosive environment.

For parameterization through the FOUNDATION Fieldbus you need suitable software, e.g. National Instruments Configurator.

#### Adjustable parameters for DS III PA and FF

Parameters	Input keys	PROFIBUS PA and FOUNDATION Fieldbus interface
Electrical damping	x	x
Zero adjustment (correction of position)	x	x
Buttons and/or function disabling	x	x
Source of measured-value display	x	x
Physical dimension of display	x	x
Position of decimal point	x	x
Bus address	x	x
Adjustment of characteristic	x	x
Input of characteristic		x
Freely-programmable LCD		x
Diagnostics functions		x

# Pressure Measurement

## Transmitters for general requirements

### SITRANS P DS III Technical description

#### Diagnostic functions for DS III PA and FF

- Event counter
- Slave pointer
- Maintenance timer
- Simulation functions
- Display of zero correction
- Limit transmitter
- Saturation alarm

#### Physical dimensions available for the display

Physical variable	Physical dimensions
Pressure (setting can also be made in the factory)	MPa, kPa, Pa, bar, mbar, torr, atm, psi, g/cm <sup>2</sup> , kg/cm <sup>2</sup> , mmH <sub>2</sub> O, mmH <sub>2</sub> O (4 °C), inH <sub>2</sub> O, inH <sub>2</sub> O (4 °C), ftH <sub>2</sub> O (20 °C), mmHg, inHg
Level (height data)	m, cm, mm, ft, in, yd
Volume	m <sup>3</sup> , dm <sup>3</sup> , hl, yd <sup>3</sup> , ft <sup>3</sup> , in <sup>3</sup> , US gallon, Imp. gallon, bushel, barrel, barrel liquid
volume flow	m <sup>3</sup> /s, m <sup>3</sup> /min, m <sup>3</sup> /h, m <sup>3</sup> /d, l/s, l/min, l/h, l/d, Ml/d, ft <sup>3</sup> /s, ft <sup>3</sup> /min, ft <sup>3</sup> /h, ft <sup>3</sup> /d, US gallon/s, US gallon/min, US gallon/h, US gallon/d, bbl/s, bbl/min, bbl/h, bbl/d
Mass flow	g/s, g/min, g/h, g/d, kg/s, kg/min, kg/h, kg/d, t/s, t/min, t/h, t/d, lb/s, lb/min, lb/h, lb/d, STon/s, STon/min, STon/h, STon/d, LTon/s, LTon/min, LTon/h, LTon/d
Total mass flow	t, kg, g, lb, oz, LTon, STon
Temperature	K, °C, °F, °R
Miscellaneous	%

# Pressure Measurement

## Transmitters for general requirements

SITRANS P DS III  
for gauge pressure

2

### Technical specifications

SITRANS P, DS III series for gauge pressure				
	HART		PROFIBUS PA and FOUNDATION Fieldbus	
<b>Input</b>				
Measured variable	Gauge pressure			
Spans (infinitely adjustable) or nominal measuring range and max. permissible test pressure	Span	Max. perm. test pressure	Nominal measuring range	Max. perm. test pressure
	0.01 ... 1 bar g (0.15 ... 14.5 psi g)	6 bar g (87 psi g)	1 bar g (14.5 psi g)	6 bar g (87 psi g)
	0.04 ... 4 bar g (0.58 ... 58 psi g)	10 bar g (145 psi g)	4 bar g (58 psi g)	10 bar g (145 psi g)
	0.16 ... 16 bar g (2.32 ... 232 psi g)	32 bar g (464 psi g)	16 bar g (232 psi g)	32 bar g (464 psi g)
	0.6 ... 63 bar g (9.14 ... 914 psi g)	100 bar g (1450 psi g)	63 bar g (914 psi g)	100 bar g (1450 psi g)
	1.6 ... 160 bar g (23.2 ... 2320 psi g)	250 bar g (3626 psi g)	160 bar g (2320 psi g)	250 bar g (3626 psi g)
	4.0 ... 400 bar g (58 ... 5802 psi g)	600 bar g (8700 psi g)	400 bar g (5802 psi g)	600 bar g (8700 psi g)
	7.0 ... 700 bar g (102 ... 10153 psi g)	800 bar g (11603 psi g)	700 bar g (10153 psi g)	800 bar g (11603 psi g)
Lower measuring limit	30 mbar a (0.435 psi a)			
<ul style="list-style-type: none"> <li>Measuring cell with silicone oil filling</li> <li>Measuring cell with inert filling liquid</li> </ul>	30 mbar a (0.435 psi a)			
Upper measuring limit	100 % of max. span (for oxygen version and inert filling liquid; max. 120 bar g (1740 psi g))			
<b>Output</b>				
Output signal	4 ... 20 mA		Digital PROFIBUS PA and FOUNDATION Fieldbus signal	
<ul style="list-style-type: none"> <li>Lower limit (infinitely adjustable)</li> <li>Upper limit (infinitely adjustable)</li> </ul>	3.55 mA, factory preset to 3.84 mA		-	
	23 mA, factory preset to 20.5 mA or optionally set to 22.0 mA		-	
Load				
<ul style="list-style-type: none"> <li>Without HART communication</li> <li>With HART communication</li> </ul>	$R_B \leq (U_H - 10.5 \text{ V})/0.023 \text{ A}$ in $\Omega$ , $U_H$ : Power supply in V		-	
	$R_B = 230 \dots 500 \Omega$ (SIMATIC PDM) or $R_B = 230 \dots 1100 \Omega$ (HART Communicator)		-	
Physical bus	-		IEC 61158-2	
Protection against polarity reversal	Protected against short-circuit and polarity reversal. Each connection against the other with max. supply voltage.			
<b>Measuring accuracy</b>				
	Acc. to EN 60770-1			
Reference conditions (All error data refer always refer to the set span)	Increasing characteristic, start-of-scale value 0 bar, stainless steel seal diaphragm, silicone oil filling, room temperature 25 °C (77 °F) r: Span ratio (r = max. span / set span)			
Error in measurement and fixed-point setting (including hysteresis and repeatability)				
<ul style="list-style-type: none"> <li>Linear characteristic</li> </ul>			≤ 0.075 %	
- r ≤ 10	≤ (0.0029 · r + 0.071) %			
- 10 < r ≤ 30	≤ (0.0045 · r + 0.071) %			
- 30 < r ≤ 100	≤ (0.005 · r + 0.05) %			
Long-term drift (temperature change ± 30 °C (± 54 °F))				
<ul style="list-style-type: none"> <li>1- to 4-bar measuring cell</li> <li>16- to 400-bar measuring cell</li> </ul>	≤ (0.25 · r) % per 5 years		≤ 0.25 · ) % per 5 years	
	≤ (0.125 · r) % per 5 years		≤ 0.125 · ) % per 5 years	
Influence of ambient temperature				
<ul style="list-style-type: none"> <li>at -10 ... +60 °C (14 ... 140 °F)</li> </ul>	≤ (0.08 · r + 0.1) % (at 700 bar: ≤ (0.1 · r + 0.2) %)		≤ 0,3 %	
<ul style="list-style-type: none"> <li>at -40 ... -10 °C and +60 ... +85 °C (-40 ... +14 °F and 140 ... 185 °F)</li> </ul>	≤ (0.1 · r + 0.15) %/10 K		≤ 0.25 %/10 K	
Measured Value Resolution	-		3 · 10 <sup>-5</sup> of nominal measuring range	

# Pressure Measurement

## Transmitters for general requirements

### SITRANS P DS III for gauge pressure

2

SITRANS P, DS III series for gauge pressure		HART	PROFIBUS PA and FOUNDATION Fieldbus
<b>Rated conditions</b>			
Degree of protection (to EN 60529)			IP65
Temperature of medium			
• Measuring cell with silicone oil filling			-40 ... +100 °C (-40 ... +212 °F)
• Measuring cell with inert filling liquid			-20 ... +100 °C (-4 ... +212 °F)
• In conjunction with dust explosion protection			-20 ... +60 °C (-4 ... +140 °F)
Ambient conditions			
• Ambient temperature			
- Digital indicator			-30 ... +85 °C (-22 ... +185 °F)
• Storage temperature			-50 ... +85 °C (-58 ... +185 °F)
• Climatic class			
- Condensation			Relative humidity 0 ... 100 % Condensation permissible, suitable for use in the tropics
• Electromagnetic Compatibility			
- Emitted interference and interference immunity			Acc. to EN 61326 and NAMUR NE 21
<b>Design</b>			
Weight (without options)			≈ 1.5 kg (≈ 3.3 lb)
Enclosure material			Low-copper die-cast aluminum, GD-AISI 12 or stainless steel precision casting, mat. no. 1.4408
Wetted parts materials			
• Connection shank			Stainless steel, mat. no. 1.4404/316L or Hastelloy C4, mat. no. 2.4610
• Oval flange			Stainless steel, mat. no. 1.4404/316L
• Seal diaphragm			Stainless steel, mat. no. 1.4404/316L or Hastelloy C276, mat. no. 2.4819
Measuring cell filling			Silicone oil or inert filling liquid (maximum value with oxygen measurement pressure 120 bar g (1740 psi g) at 60 °C (140 °F))
Process connection			Connection shank G $\frac{1}{2}$ B to DIN EN 837-1, female thread $\frac{1}{2}$ -14 NPT or oval flange (PN 160 (MWP 2320 psi g)) to DIN 19213 with mounting thread M10 or $\frac{7}{16}$ -20 UNF to EN 61518
Material of mounting bracket			
Steel			Sheet-steel, Mat. No. 1.0330, chrome-plated
Stainless steel			Sheet stainless steel, mat. no. 1.4301 (SS 304)
<b>Power supply <math>U_H</math></b>			Supplied through bus
Terminal voltage on transmitter	10.5 ... 45 V DC 10.5 ... 30 V DC in intrinsically-safe mode		-
Separate 24 V power supply necessary	-		No
Bus voltage			
• Not Ex	-		9 ... 32 V
• With intrinsically-safe operation	-		9 ... 24 V
Current consumption			
• Basic current (max.)	-		12.5 mA
• Start-up current $\leq$ basic current	-		Yes
• Max. current in event of fault	-		15.5 mA
Fault disconnection electronics (FDE) available	-		Yes

# Pressure Measurement

## Transmitters for general requirements

SITRANS P DS III  
for gauge pressure

### SITRANS P, DS III series for gauge pressure

	HART	PROFIBUS PA and FOUNDATION Fieldbus
<b>Certificates and approvals</b>		
Classification according to PED 97/23/EC	For gases of fluid group 1 and liquids of fluid group 1; complies with requirements of article 3, paragraph 3 (sound engineering practice)	
Explosion protection		
• Intrinsic safety "i"		PTB 99 ATEX 2122
- Marking		Ex II 1/2 G EEx ia/ib IIB/IIC T6
- Permissible ambient temperature		-40 ... +85 °C (-40 ... +185 °F) temperature class T4; -40 ... +70 °C (-40 ... +158 °F) temperature class T5; -40 ... +60 °C (-40 ... +140 °F) temperature class T6
- Connection	To certified intrinsically-safe circuits with peak values: $U_i = 30 \text{ V}$ , $I_i = 100 \text{ mA}$ , $P_i = 750 \text{ mW}$ ; $R_i = 300 \Omega$	FISCO supply unit: $U_o = 17.5 \text{ V}$ , $I_o = 380 \text{ mA}$ , $P_o = 5.32 \text{ W}$ Linear barrier: $U_o = 24 \text{ V}$ , $I_o = 250 \text{ mA}$ , $P_o = 1.2 \text{ W}$
- Effective internal inductance/capacitance	$L_i = 0.4 \text{ mH}$ , $C_i = 6 \text{ nF}$	$L_i = 7 \mu\text{H}$ , $C_i = 1.1 \text{ nF}$
• Explosion-proof "d"		PTB 99 ATEX 1160
- Marking		Ex II 1/2 G EEx d IIC T4/T6
- Permissible ambient temperature		-40 ... +85 °C (-40 ... +185 °F) temperature class T4; -40 ... +60 °C (-40 ... +140 °F) temperature class T6
- Connection	To circuits with values: $U_H = 10.5 \dots 45 \text{ V DC}$	To circuits with values: $U_H = 9 \dots 32 \text{ V DC}$
• Dust explosion protection for zone 20		PTB 01 ATEX 2055
- Marking		Ex II 1 D IP65 T 120 °C Ex II 1/2 D IP65 T 120 °C
- Permissible ambient temperature		-40 ... +85 °C (-40 ... +185 °F)
- Max. surface temperature		120 °C (248 °F)
- Connection	To certified intrinsically-safe circuits with peak values: $U_i = 30 \text{ V}$ , $I_i = 100 \text{ mA}$ , $P_i = 750 \text{ mW}$ , $R_i = 300 \Omega$	FISCO supply unit: $U_o = 17.5 \text{ V}$ , $I_o = 380 \text{ mA}$ , $P_o = 5.32 \text{ W}$ Linear barrier: $U_o = 24 \text{ V}$ , $I_o = 250 \text{ mA}$ , $P_o = 1.2 \text{ W}$
- Effective internal inductance/capacitance	$L_i = 0.4 \text{ mH}$ , $C_i = 6 \text{ nF}$	$L_i = 7 \mu\text{H}$ , $C_i = 1.1 \text{ nF}$
• Dust explosion protection for zone 21/22		PTB 01 ATEX 2055
- Marking		Ex II 2 D IP65 T 120 °C
- Connection	To circuits with values: $U_H = 10.5 \dots 45 \text{ V DC}$ ; $P_{\max} = 1.2 \text{ W}$	To circuits with values: $U_H = 9 \dots 32 \text{ V DC}$ ; $P_{\max} = 1.2 \text{ W}$
• Type of protection "n" (zone 2)	TÜV 01 ATEX 1696 X	Planned
- Marking	Ex II 3 G EEx nA L IIC T4/T5/T6	-
• Explosion protection acc. to FM		Certificate of Compliance 3008490
- Identification (XP/DIP) or (IS); (NI)		CL I, DIV 1, GP ABCD T4...T6; CL II, DIV 1, GP EFG; CL III; CL I, ZN 0/1 AEx ia IIC T4...T6; CL I, DIV 2, GP ABCD T4...T6; CL II, DIV 2, GP FG; CL III
• Explosion protection to CSA		Certificate of Compliance 1153651
- Identification (XP/DIP) or (IS)		CL I, DIV 1, GP ABCD T4...T6; CL II, DIV 1, GP EFG; CL III; Ex ia IIC T4...T6; CL I, DIV 2, GP ABCD T4...T6; CL II, DIV 2, GP FG; CL III

# Pressure Measurement

## Transmitters for general requirements

### SITRANS P DS III for gauge pressure

2

#### HART communication

HART communication	230 ... 1100 Ω
Protocol	HART Version 5.x
Software for computer	SIMATIC PDM

#### PROFIBUS PA communication

Simultaneous communication with master class 2 (max.)	4
The address can be set using	Configuration tool or local operation (standard setting address 126)
Cyclic data usage	
• Output byte	5 (one measured value) or 10 (two measured values)
• Input byte	0, 1, or 2 (register operating mode and reset function for metering)
Internal preprocessing	
Device profile	PROFIBUS PA Profile for Process Control Devices Version 3.0, Class B
Function blocks	2
• Analog input	
- Adaptation to customer-specific process variables	Yes, linearly rising or falling characteristic
- Electrical damping $T_{63}$ , adjustable	0 ... 100 s
- Simulation function	Input /Output
- Failure mode	parameterizable (last good value, substitute value, incorrect value)
- Limit monitoring	Yes, one upper and lower warning limit and one alarm limit respectively
• Register (totalizer)	Can be reset, preset, optional direction of counting, simulation function of register output
- Failure mode	parameterizable (summation with last good value, continuous summation, summation with incorrect value)
- Limit monitoring	One upper and lower warning limit and one alarm limit respectively
• Physical block	1
Transducer blocks	2
• Pressure transducer block	
- Can be calibrated by applying two pressures	Yes
- Monitoring of sensor limits	Yes
- Specification of a container characteristic with	Max. 30 nodes
- Square-rooted characteristic for flow measurement	Yes
- Gradual volume suppression and implementation point of square-root extraction	Parameterizable
- Simulation function for measured pressure value and sensor temperature	Constant value or over parameterizable ramp function

#### FOUNDATION Fieldbus communication

Function blocks	3 function blocks analog input, 1 function block PID
• Analog input	
- Adaptation to customer-specific process variables	Yes, linearly rising or falling characteristic
- Electrical damping $T_{63}$ , adjustable	0 ... 100 s
- Simulation function	Output/input (can be locked within the device with a bridge)
- Failure mode	parameterizable (last good value, substitute value, incorrect value)
- Limit monitoring	Yes, one upper and lower warning limit and one alarm limit respectively
- Square-rooted characteristic for flow measurement	Yes
• PID	Standard FF function block
• Physical block	1 resource block
Transducer blocks	1 transducer block Pressure with calibration, 1 transducer block LCD
• Pressure transducer block	
- Can be calibrated by applying two pressures	Yes
- Monitoring of sensor limits	Yes
- Simulation function: Measured pressure value, sensor temperature and electronics temperature	Constant value or over parameterizable ramp function

# Pressure Measurement

## Transmitters for general requirements

**SITRANS P DS III**  
**for gauge pressure**

Selection and Ordering data		Order No.
<b>Pressure transmitter for gauge pressure, SITRANS P DS III HART</b>		<b>7MF4033-</b>
<b>Measuring cell filling</b>	<b>Measuring cell cleaning</b>	
Silicone oil	normal	▶ 1
Inert liquid <sup>1)</sup>	Grease-free	▶ 3
<b>Measuring span</b>		
0.01 ... 1 bar g	(0.15 ... 14.5 psi g)	▶ B
0.04 ... 4 bar g	(0.58 ... 58 psi g)	▶ C
0.16 ... 16 bar g	(2.32 ... 232 psi g)	▶ D
0.63 ... 63 bar g	(9.14 ... 914 psi g)	▶ E
1.6 ... 160 bar g	(23.2 ... 2320 psi g)	▶ F
4.0 ... 400 bar g	(58.0 ... 5802 psi g)	▶ G
7.0 ... 700 bar g	(102.0 ... 10153 psi g)	▶ J
<b>Wetted parts materials</b>		
Seal diaphragm	Process connection	
Stainless steel	Stainless steel	▶ A
Hastelloy	Stainless steel	B
Hastelloy	Hastelloy	C
Version as diaphragm seal <sup>2)3)</sup>		Y
<b>Process connection</b>		
• Connection shank G $\frac{1}{2}$ B to EN 837-1		▶ 0
• Female thread $\frac{1}{2}$ -14 NPT		1
• Stainless steel oval flange		
- Mounting thread $\frac{7}{16}$ -20 UNF to EN 61518		2
- Mounting thread M10 to DIN 19213		3
- Mounting thread M12 to DIN 19213		4
• Male thread M20 x 1.5		5
• Male thread $\frac{1}{2}$ -14 NPT		6
<b>Non-wetted parts materials</b>		
• Housing made of die-cast aluminium		▶ 0
• Housing stainless steel precision casting <sup>4)</sup>		3
<b>Version</b>		
• Standard versions		1
• International version, English label inscriptions, documentation in 5 languages on CD		▶ 2
<b>Explosion protection</b>		
• None		A
• With ATEX, Type of protection:		
- "Intrinsic safety (EEx ia)"		B
- "Explosion-proof (EExd) <sup>5)</sup>		D
- "Intrinsic safety and flameproof enclosure (EEx ia + EEx d) <sup>6)</sup>		P
- "Ex nA/nL (Zone 2)"		E
- "Intrinsic safety, explosion-proof enclosure and dust explosion protection (EEx ia + EEx d + Zone 1D/2D) <sup>6)</sup>		▶ R
• With FM + CSA, Type of protection:		
- "Intrinsic Safe und Explosion Proof (is + xp) <sup>5)</sup>		NC
<b>Electrical connection / cable entry</b>		
• Screwed gland Pg 13.5 (adapter) <sup>7)</sup>		A
• Screwed gland M20 x1 .5		▶ B
• Screwed gland $\frac{1}{2}$ -14 NPT		C
• Han 7D plug (plastic housing) incl. mating connector <sup>7)</sup>		D
• M12 connectors (metal) <sup>8)</sup>		F

Selection and Ordering data		Order No.
<b>Pressure transmitter for gauge pressure, SITRANS P DS III HART</b>		<b>7MF4033-</b>
<b>Display</b>		
• Without indicator		0
• Without visible digital indicator (digital indicator concealed, setting: mA)		▶ 1
• With visible digital indicator, setting: mA		6
• with customer-specific digital indicator (setting as specified, Order Code "Y21" or "Y22" required)		7
▶ Available ex stock		
Power supply units see Chap. 8 "Supplementary Components".		
Included in delivery of the device:		
• Brief instructions (Leporello)		
• CD-ROM with detailed documentation		
1) For oxygen application, add Order code E10.		
2) When the manufacture's certificate (calibration certificate) has to be ordered for transmitters with diaphragm seals according to IEC 60770-2, it is recommended only to order this certificate exclusively with the diaphragm seals. The measuring accuracy of the <u>total</u> combination is certified here.		
3) If the acceptance test certificate 3.1 is ordered for the transmitter with mounted diaphragm seals this certificate must also be ordered with the respective remote seals.		
4) Not in conjunction with Electrical connection "Screwed gland Pg 13.5" and "Han7D plug".		
5) Without cable gland, with blanking plug		
6) With enclosed cable gland EEx ia and blanking plug		
7) Not in conjunction with types of protection "Explosion-proof" and "Ex nA", "Intrinsic safety" and "Explosion-proof".		
8) M12 delivered without cable socket		



# Pressure Measurement

## Transmitters for general requirements

**SITRANS P DS III**  
 for gauge pressure

Selection and Ordering data	Order code			
<b>Further designs</b> Add "-Z" to Order No. and specify Order Code.		<b>HART</b>	<b>PA</b>	<b>FF</b>
<b>Pressure transmitter with mounting bracket (2 shackles, 4 nuts, 4 U-plates, 1 angle) made of:</b>				
• Steel	<b>A01</b>	✓	✓	✓
• Stainless steel	<b>A02</b>	✓	✓	✓
<b>plug</b>				
• Han 7D (metal, gray)	<b>A30</b>	✓		
• Han 8U (instead of Han 7D)	<b>A31</b>	✓		
• Angled	<b>A32</b>	✓		
• Han 8D (metal, gray)	<b>A33</b>	✓		
<b>Cable sockets for M12 connectors (metal)</b>	<b>A50</b>	✓	✓	✓
<b>Rating plate inscription</b> (instead of German)				
• English	<b>B11</b>	✓	✓	✓
• French	<b>B12</b>	✓	✓	✓
• Spanish	<b>B13</b>	✓	✓	✓
• Italian	<b>B14</b>	✓	✓	✓
<b>English rating plate</b> Pressure units in inH <sub>2</sub> O and/or psi	<b>B21</b>	✓	✓	✓
<b>Quality inspection certificate (factory calibration) to IEC 60770-2<sup>1)</sup></b>	<b>C11</b>	✓	✓	✓
<b>Inspection certificate<sup>2)</sup></b> Acc. to EN 10204-3.1	<b>C12</b>	✓	✓	✓
<b>Factory certificate</b> Acc. to EN 10204-2.2	<b>C14</b>	✓	✓	✓
<b>"Functional safety (SIL2)" certificate</b>	<b>C20</b>	✓		
<b>PROFIsafe certificate and protocol</b>	<b>C21</b>		✓	
<b>"Functional safety (SIL2/3)" certificate</b>	<b>C23</b>	✓		
<b>Setting of upper limit of output signal to 22.0 mA</b>	<b>D05</b>	✓		
<b>Manufacturer's declaration acc. to NACE</b>	<b>D07</b>	✓	✓	✓
<b>Degree of protection IP68</b> (only for M20x1.5 and 1/2-14 NPT)	<b>D12</b>	✓	✓	✓
<b>Supplied with oval flange</b> (1 item), PTFE packing and screws in thread of oval flange	<b>D37</b>	✓	✓	✓
<b>Use in or on zone 1D/2D</b> (only together with type of protection "Intrinsic safety (EEx ia)")	<b>E01</b>	✓	✓	✓
<b>Oxygen application</b> (In the case of oxygen measurement and inert liquid max. 120 bar G (1740 psi G) at 60°C (140 °F))	<b>E10</b>	✓	✓	✓
<b>Explosion-proof "Intrinsic safety" to INMETRO (Brazil)</b> (only for transmitter 7MF4...-.....-B..)	<b>E25</b>	✓	✓	✓
<b>Ex Approval IEC Ex (EEx ia)</b> (only for transmitter 7MF4...-.....-B..)	<b>E45</b>	✓	✓	✓
<b>Ex Approval IEC Ex (EEx id)</b> (only for transmitter 7MF4...-.....-D..)	<b>E46</b>	✓	✓	✓
<b>Explosion-proof "Intrinsic safety" to NEPSI (China)</b> (only for transmitter 7MF4...-.....-B..)	<b>E55</b>	✓	✓	✓
<b>Explosion protection "Explosion-proof" to NEPSI (China)</b> (only for transmitter 7MF4...-.....-D..)	<b>E56</b>	✓	✓	✓
<b>Ex protection "Zone 2" to NEPSI (China)</b> (only for transmitter 7MF4...-.....-E..)	<b>E57</b>	✓	✓	✓
<b>Two coats of lacquer on casing and cover (PU on epoxy)</b>	<b>G10</b>	✓	✓	✓

Selection and Ordering data	Order code			
<b>Additional data</b> Please add "-Z" to Order No. and specify Order code(s) and plain text.		<b>HART</b>	<b>PA</b>	<b>FF</b>
<b>Measuring range to be set</b> Specify in plain text (max. 5 characters): Y01: ... up to ... mbar, bar, kPa, MPa, psi	<b>Y01</b>	✓		
<b>Stainless steel tag plate (measuring point description)</b> Max. 16 characters, specify in plain text: Y15: .....	<b>Y15</b>	✓	✓	✓
<b>Measuring point text</b> Max. 27 characters, specify in plain text: Y16: .....	<b>Y16</b>	✓	✓	✓
<b>Entry of HART address (TAG)</b> Max. 8 characters, specify in plain text: Y17: .....	<b>Y17</b>	✓		
<b>Setting of pressure indication in pressure units</b> Specify in plain text (standard setting: bar): Y21: mbar, bar, kPa, MPa, psi, ... Note: The following pressure units can be selected: bar, mbar, mm H <sub>2</sub> O <sup>1)</sup> , inH <sub>2</sub> O <sup>1)</sup> , ftH <sub>2</sub> O <sup>1)</sup> , mmHG, inHG, psi, Pa, kPa, MPa, g/cm <sup>2</sup> , kg/cm <sup>2</sup> , Torr, ATM or % ) ref. temperature 20 °C	<b>Y21</b>	✓	✓	✓
<b>Setting of pressure indication in non-pressure units<sup>3)</sup></b> Specify in plain text: Y22: ..... up to ..... l/min, m <sup>3</sup> /h, m, USgpm, ... (specification of measuring range in pressure units "Y01" is essential, unit with max. 5 characters)	<b>Y22 + Y01</b>	✓		
<b>Preset bus address</b> possible between 1 and 126 Specify in plain text: Y25: .....	<b>Y25</b>		✓	

Factory mounting of valve manifolds, see accessories.

Only "Y01", "Y21", "Y22", "Y25" and "D05" can be factory preset

✓ = available

**ordering example**

 Item line: 7MF4033-1EA00-1AA7-Z  
 B line: A01 + Y01 + Y21  
 C line: Y01: 10 ... 20 bar (145 ... 290 psi)  
 C line: Y21: bar (psi)

<sup>1)</sup> When the manufacturer's certificate (calibration certificate) has to be ordered for transmitters with diaphragm seals according to IEC 60770-2, it is recommended only to order this certificate exclusively with the diaphragm seals. The measuring accuracy of the total combination is certified here.

<sup>2)</sup> If the acceptance test certificate 3.1 is ordered for the transmitter with mounted diaphragm seals this certificate must also be ordered with the respective remote seals.

<sup>3)</sup> Preset values can only be changed over SIMATIC PDM.

# Pressure Measurement

## Transmitters for general requirements

SITRANS P DS III  
for gauge pressure

### Dimensional drawings

2

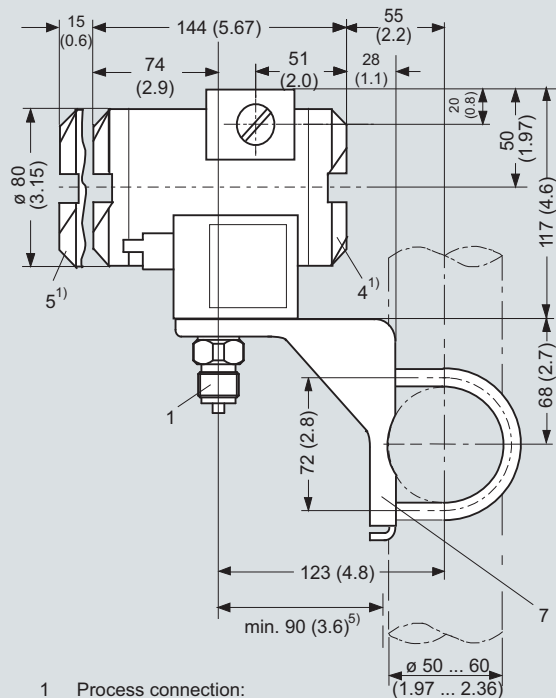

- 1 Process connection:
  - 1/2-14 NPT,
  - Connection shank G 1/2 B or
  - Oval flange
- 2 Blanking plug
- 3 Electrical connection:
  - Screwed gland Pg 13,5 (adapter)<sup>2) 3)</sup>, only DS III HART,
  - Screwed gland M20x1,5<sup>3)</sup>,
  - Screwed gland 1/2-14 NPT,
  - Han 7D/Han 8D<sup>2) 3)</sup> plug, only DS III HART, or
  - M12 connector
- 4 Terminal side
- 5 Electronic side, digital display (longer overall length for cover with window)
- 6 Protective cover over keys
- 7 Mounting bracket (option)
- 8 Screw cover - safety bracket (only for type of protection "Explosion-proof enclosure", not shown in the drawing)

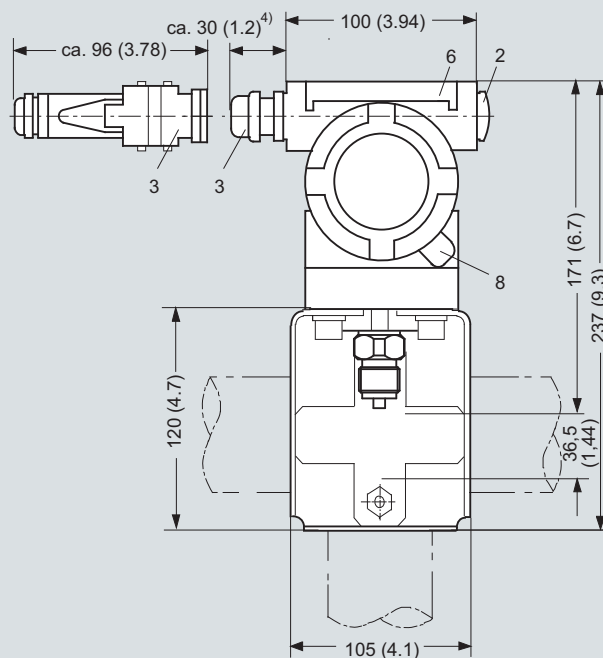

- 1) Allow approx. 20 mm (0.79 inch) thread length to permit unscrewing
- 2) Not with type of protection "Explosion-proof enclosure"
- 3) Not with type of protection "FM + CSA" [is + xp]
- 4) For Pg 13,5 with adapter approx. 45 mm (1.77 inch)
- 5) Minimum distance for rotating

SITRANS P DS III pressure transmitters for gauge pressure, dimensions in mm (inch)

# Pressure Measurement

## Transmitters for general requirements

SITRANS P DS III for gauge/absolute pressure,  
with front-flush diaphragm

### Technical specifications

SITRANS P DS III series for gauge and absolute pressure, with front-flush diaphragm				
	HART		PROFIBUS PA and FOUNDATION Fieldbus	
<b>Input of gauge pressure, with front-flush diaphragm</b>				
Measured variable	Gauge pressure, front-flush			
Spans (infinitely adjustable) or nominal measuring range and max. permissible test pressure	Span	Max. perm. test pressure	Nominal measuring range	Max. perm. test pressure
	0.01 ... 1 bar g (0.15 ... 14.5 psi g)	6 bar g (87 psi g)	1 bar g (14.5 psi g)	6 bar g (87 psi g)
	0.04 ... 4 bar g (0.58 ... 58 psi g)	10 bar g (145 psi g)	4 bar g (58 psi g)	10 bar g (145 psi g)
	0.16 ... 16 bar g (2.32 ... 232 psi g)	32 bar g (464 psi g)	16 bar g (232 psi g)	32 bar g (464 psi g)
	0.6 ... 63 bar g (9.14 ... 914 psi g)	100 bar g (1450 psi g)	63 bar g (914 psi g)	100 bar g (1450 psi g)
Lower measuring limit	-100 mbar g (-1.45 psi g)			
Upper measuring limit	100 % of max. span		100 % of the max. nominal measuring range	
<b>Input of absolute pressure, with front-flush diaphragm</b>				
Measured variable	Absolute pressure, front-flush			
Spans (infinitely adjustable) or nominal measuring range and max. permissible test pressure	Span	Max. perm. test pressure	Nominal measuring range	Max. perm. test pressure
	43 ... 1300 mbar a (0.62 ... 18.9 psi a)	10 bar a (145 psi a)	1300 mbar a (18.9 psi a)	10 bar a (145 psi a)
	0.16 ... 5 bar a (2.32 ... 72.5 psi a)	30 bar a (435 psi a)	5 bar a (72.5 psi a)	30 bar a (435 psi a)
	1 ... 30 bar a (14.5 ... 435 psi a)	100 bar a (1450 psi a)	30 bar a (435 psi a)	100 bar a (1450 psi a)
Lower measuring limit	0 bar a (0 psi a)			
Upper measuring limit	100 % of max. span		100 % of the max. nominal measuring range	
<b>Output</b>				
Output signal	4 ... 20 mA		Digital PROFIBUS PA and FOUNDATION Fieldbus signal	
• Lower limit (infinitely adjustable)	3.55 mA, factory preset to 3.84 mA		-	
• Upper limit (infinitely adjustable)	23 mA, factory preset to 20.5 mA or optionally set to 22.0 mA		-	
Load				
• Without HART communication	$R_B \leq (U_H - 10.5 \text{ V})/0.023 \text{ A}$ in $\Omega$ , $U_H$ : Power supply in V		-	
• With HART communication	$R_B = 230 \dots 500 \Omega$ (SIMATIC PDM) or $R_B = 230 \dots 1100 \Omega$ (HART Communicator)		-	
Physical bus	-		IEC 61158-2	
Protection against polarity reversal	Protected against short-circuit and polarity reversal. Each connection against the other with max. supply voltage.			
<b>Measuring accuracy</b>				
Reference conditions (All error data refer always refer to the set span)	Acc. to EN 60770-1 Increasing characteristic, start-of-scale value 0 bar, stainless steel seal diaphragm, silicone oil filling, room temperature 25 °C (77 °F) r: Span ratio (r = max. span / set span)			
Error in measurement and fixed-point setting (including hysteresis and repeatability)	Gauge pressure, front-flush	Absolute pressure, front-flush	Gauge pressure, front-flush	Absolute pressure, front-flush
• Linear characteristic			$\leq 0.075 \%$	$\leq 0.2 \%$
- $r \leq 10$	$\leq (0.0029 \cdot r + 0.071) \%$	$\leq 0.2 \%$		
- $10 < r \leq 30$	$\leq (0.0045 \cdot r + 0.071) \%$	$\leq 0.4 \%$		
- $30 < r \leq 100$	$\leq (0.005 \cdot r + 0.05) \%$			
Long-term drift (temperature change $\pm 30 \text{ °C}$ ( $\pm 54 \text{ °F}$ ))	$\leq (0.25 \cdot r) \%$ per 5 years		$\leq 0.25 \%$ per 5 years	

# Pressure Measurement

## Transmitters for general requirements

### SITRANS P DS III for gauge/absolute pressure, with front-flush diaphragm

2

SITRANS P DS III series for gauge and absolute pressure, with front-flush diaphragm				
	HART		PROFIBUS PA and FOUNDATION Fieldbus	
Influence of ambient temperature				
• at -10 ... +60 °C (14 ... 140 °F)	$\leq (0.1 \cdot r + 0.2) \%$	$\leq (0.2 \cdot r + 0.3) \%$	$\leq 0.3 \%$	$\leq 0.5 \%$
• at -40 ... -10 °C and 60 ... 85 °C (-40 ... +14 °F and 140 ... 185 °F)	$\leq (0.1 \cdot r + 0.15) \%/10$ K	$\leq (0.2 \cdot r + 0.3) \%/10$ K	$\leq 0.25 \%/10$ K	$\leq 0.5 \%/10$ K
Influence of mounting position		0.1 mbar g (0.00145 psi g) per 10° inclination		
Measured Value Resolution	-		$3 \cdot 10^{-5}$ of nominal measuring range	
Influence of the medium temperature (only with front-flush diaphragm)				
• Temperature difference between medium temperature and ambient temperature		3 mbar/10 K (0.04 psi/10 K)		
<b>Rated conditions</b>				
<u>Installation conditions</u>				
Ambient temperature	Observe the temperature class in areas subject to explosion hazard.			
• Measuring cell with silicone oil	-40 ... +85 °C (-40 ... +185 °F)			
• Measuring cell with Neobee oil (with front-flush diaphragm)	-10 ... +85 °C (14 ... +185 °F)			
• Measuring cell with inert liquid (not with front-flush diaphragm)	-20 ... +85 °C (-4 ... +185 °F)			
• Digital display	-30 ... +85 °C (-22 ... +185 °F)			
• Storage temperature	-50 ... +85 °C (-58 ... +185 °F) (in the case of Neobee: -20 ... +85 °C (-4 ... +185/°F))			
• Climatic class	Relative humidity 0 ... 100 %			
- Condensation	Condensation permissible, suitable for use in the tropics			
Degree of protection (to EN 60529)	IP65, IP68, NEMA 4X, enclosure cleaning, resistant to lyes, steam to 150 °C (302 °F)			
• Electromagnetic Compatibility	Acc. to EN 61326 and NAMUR NE 21			
- Emitted interference and interference immunity				
<u>Medium conditions</u>				
Temperature of medium				
• Measuring cell with silicone oil	-40 ... +100 °C (-40 ... +212 °F)			
• Measuring cell with silicone oil (with front-flush diaphragm)	-40 ... +150 °C (-40 ... +302 °F)			
• Measuring cell with Neobee oil (with front-flush diaphragm)	-10 ... +150 °C (14 ... 302 °F)			
• Measuring cell with silicone oil, with temperature decoupler (only with front-flush diaphragm)	-40 ... +200 °C (-40 ... +392 °F)			
• Measuring cell with inert liquid	-20 ... +100 °C (-4 ... +212 °F)			
• Measuring cell with high-temperature oil	-10 ... +250 °C (14 ... 482 °F)			
<b>Design</b>				
Weight (without options)	≈ 1.5 kg (≈ 3.3 lb)			
Enclosure material	Low-copper die-cast aluminum, GD-ALSi12 or stainless steel precision casting, mat. no. 1.4408			
Wetted parts materials	Stainless steel, mat. no. 1.4404/316L			
Measuring cell filling	Silicone oil or inert filling liquid			
Process connection	<ul style="list-style-type: none"> <li>• Flanges as per EN and ASME</li> <li>• F&amp;B and pharmaceutical flanges</li> </ul>			
Surface quality touched-by-media	$R_a$ -values $\leq 0.8 \mu\text{m}$ (32 $\mu$ -inch)/welds $R_a \leq 1.6 \mu\text{m}$ (64 $\mu$ -inch) (Process connections according to 3A; $R_a$ -values $\leq 0,8 \mu\text{m}$ (32 $\mu$ -inch)/welds $R_a \leq 0,8 \mu\text{m}$ (32 $\mu$ -inch))			

# Pressure Measurement

## Transmitters for general requirements

SITRANS P DS III for gauge/absolute pressure,  
with front-flush diaphragm

SITRANS P DS III series for gauge and absolute pressure, with front-flush diaphragm		
	HART	PROFIBUS PA and FOUNDATION Fieldbus
<b>Power supply <math>U_H</math></b>		
Terminal voltage on transmitter	10.5 ... 45 V DC 10.5 ... 30 V DC in intrinsically-safe mode	Supplied through bus -
Separate 24 V power supply necessary	-	No
Bus voltage		
• Not Ex	-	9 ... 32 V
• With intrinsically-safe operation	-	9 ... 24 V
Current consumption		
• Basic current (max.)	-	12.5 mA
• Start-up current $\leq$ basic current	-	Yes
• Max. current in event of fault	-	15.5 mA
Fault disconnection electronics (FDE) available	-	Yes
<b>Certificates and approvals</b>		
Classification according to PED 97/23/EC	For gases of fluid group 1 and liquids of fluid group 1; complies with requirements of article 3, paragraph 3 (sound engineering practice)	
Explosion protection		
• Intrinsic safety "i"	PTB 99 ATEX 2122	
- Marking	Ex II 1/2 G EEx ia/ib IIB/IIC T6	
- Permissible ambient temperature	-40 ... +85 °C (-40 ... +185 °F) temperature class T4; -40 ... +70 °C (-40 ... +158 °F) temperature class T5; -40 ... +60 °C (-40 ... +140 °F) temperature class T6	
- Connection	To certified intrinsically-safe circuits with peak values: $U_i = 30$ V, $I_i = 100$ mA, $P_i = 750$ mW; $R_i = 300$ $\Omega$	FISCO supply unit: $U_o = 17.5$ V, $I_o = 380$ mA, $P_o = 5.32$ W Linear barrier: $U_o = 24$ V, $I_o = 250$ mA, $P_o = 1.2$ W
- Effective internal inductance/capacitance	$L_i = 0.4$ mH, $C_i = 6$ nF	$L_i = 7$ $\mu$ H, $C_i = 1.1$ nF
• Explosion-proof "d"	PTB 99 ATEX 1160	
- Marking	Ex II 1/2 G EEx d IIC T4/T6	
- Permissible ambient temperature	-40 ... +85 °C (-40 ... +185 °F) temperature class T4; -40 ... +60 °C (-40 ... +140 °F) temperature class T6	
- Connection	To circuits with values: $U_H = 10.5$ ... 45 V DC	To circuits with values: $U_H = 9$ ... 32 V DC
• Dust explosion protection for zone 20	PTB 01 ATEX 2055	
- Marking	Ex II 1 D IP65 T 120 °C Ex II 1/2 D IP65 T 120 °C	
- Permissible ambient temperature	-40 ... +85 °C (-40 ... +185 °F)	
- Max. surface temperature	120 °C (248 °F)	
- Connection	To certified intrinsically-safe circuits with peak values: $U_i = 30$ V, $I_i = 100$ mA, $P_i = 750$ mW, $R_i = 300$ $\Omega$	FISCO supply unit: $U_o = 17.5$ V, $I_o = 380$ mA, $P_o = 5.32$ W Linear barrier: $U_o = 24$ V, $I_o = 250$ mA, $P_o = 1.2$ W
- Effective internal inductance/capacitance	$L_i = 0.4$ mH, $C_i = 6$ nF	$L_i = 7$ $\mu$ H, $C_i = 1.1$ nF
• Dust explosion protection for zone 21/22	PTB 01 ATEX 2055	
- Marking	Ex II 2 D IP65 T 120 °C	
- Connection	To circuits with values: $U_H = 10.5$ ... 45 V DC; $P_{max} = 1.2$ W	To circuits with values: $U_H = 9$ ... 32 V DC; $P_{max} = 1.2$ W
• Type of protection "n" (zone 2)	TÜV 01 ATEX 1696 X	Planned
- Marking	Ex II 3 G EEx nA L IIC T4/T5/T6	-
• Explosion protection acc. to FM	Certificate of Compliance 3008490	
- Identification (XP/DIP) or (IS); (NI)	CL I, DIV 1, GP ABCD T4...T6; CL II, DIV 1, GP EFG; CL III; CL I, ZN 0/1 AEx ia IIC T4...T6; CL I, DIV 2, GP ABCD T4...T6; CL II, DIV 2, GP FG; CL III	
• Explosion protection to CSA	Certificate of Compliance 1153651	
- Identification (XP/DIP) or (IS)	CL I, DIV 1, GP ABCD T4...T6; CL II, DIV 1, GP EFG; CL III; Ex ia IIC T4...T6; CL I, DIV 2, GP ABCD T4...T6; CL II, DIV 2, GP FG; CL III	

# Pressure Measurement

## Transmitters for general requirements

### SITRANS P DS III for gauge/absolute pressure, with front-flush diaphragm

#### Hygiene version

In the case of SITRANS P DSIII with 7MF413x front-flush diaphragm, selected connections comply with the requirements of EHEDG.

<b>HART communication</b>		<b>FOUNDATION Fieldbus communication</b>	
HART communication	230 ... 1100 Ω	Function blocks	3 function blocks analog input, 1 function block PID
Protocol	HART Version 5.x	• Analog input	Yes, linearly rising or falling characteristic
Software for computer	SIMATIC PDM	- Adaptation to customer-specific process variables	0 ... 100 s
<b>PROFIBUS PA communication</b>		- Electrical damping $T_{63}$ , adjustable	Output/input (can be locked within the device with a bridge)
Simultaneous communication with master class 2 (max.)	4	- Simulation function	parameterizable (last good value, substitute value, incorrect value)
The address can be set using	Configuration tool or local operation (standard setting address 126)	- Failure mode	Yes, one upper and lower warning limit and one alarm limit respectively
Cyclic data usage		- Limit monitoring	Yes
• Output byte	5 (one measured value) or 10 (two measured values)	- Square-rooted characteristic for flow measurement	Standard FF function block
• Input byte	0, 1, or 2 (register operating mode and reset function for metering)	• PID	1 resource block
Internal preprocessing		• Physical block	1 transducer block Pressure with calibration, 1 transducer block LCD
Device profile	PROFIBUS PA Profile for Process Control Devices Version 3.0, Class B	Transducer blocks	
Function blocks	2	• Pressure transducer block	
• Analog input		- Can be calibrated by applying two pressures	Yes
- Adaptation to customer-specific process variables	Yes, linearly rising or falling characteristic	- Monitoring of sensor limits	Yes
- Electrical damping $T_{63}$ , adjustable	0 ... 100 s	- Simulation function: Measured pressure value, sensor temperature and electronics temperature	Constant value or over parameterizable ramp function
- Simulation function	Input /Output		
- Failure mode	parameterizable (last good value, substitute value, incorrect value)		
- Limit monitoring	Yes, one upper and lower warning limit and one alarm limit respectively		
• Register (totalizer)	Can be reset, preset, optional direction of counting, simulation function of register output		
- Failure mode	parameterizable (summation with last good value, continuous summation, summation with incorrect value)		
- Limit monitoring	One upper and lower warning limit and one alarm limit respectively		
• Physical block	1		
Transducer blocks	2		
• Pressure transducer block			
- Can be calibrated by applying two pressures	Yes		
- Monitoring of sensor limits	Yes		
- Specification of a container characteristic with	Max. 30 nodes		
- Square-rooted characteristic for flow measurement	Yes		
- Gradual volume suppression and implementation point of square-root extraction	Parameterizable		
- Simulation function for measured pressure value and sensor temperature	Constant value or over parameterizable ramp function		

# Pressure Measurement

## Transmitters for general requirements

SITRANS P DS III for gauge/absolute pressure, with front-flush diaphragm

2

Selection and Ordering data		Order No.
<b>Pressure transmitter for gauge and absolute pressure, front-flush diaphragm, SITRANS P DS III HART</b>		F) 7MF4133 -
<b>Measuring cell filling</b>	<b>Measuring cell cleaning</b>	
Silicone oil	normal	1
Inert liquid	Grease-free	3
FDA compliant fill fluid		
• Neobee oil	normal	4
<b>Measuring span</b>		
0,01 ... 1 bar g	(0.15 ... 14.5 psi g)	B
0,04 ... 4 bar g	(0.58 ... 58 psi g)	C
0,16 ... 16 bar g	(2.32 ... 232 psi g)	D
0,63 ... 63 bar g	(9.14 ... 914 psi g)	E
13 ... 1300 mbar a <sup>1)</sup>	(0.19 ... 18.9 psi a <sup>1)</sup> )	S
0,05 ... 5 bar a <sup>1)</sup>	(0.7 ... 72.5 psi a <sup>1)</sup> )	T
0,3 ... 30 bar a <sup>1)</sup>	(4.35 ... 435 psi a <sup>1)</sup> )	U
<b>Wetted parts materials</b>		
Seal diaphragm	Connection shank	
Stainless steel	Stainless steel	A
Hastelloy <sup>2)</sup>	Stainless steel	B
<b>Process connection</b>		
• Flange version with Order Code M., N., R. or Q..		7
<b>Non-wetted parts materials</b>		
• Housing made of die-cast aluminium		0
• Housing stainless steel precision casting		3
<b>Version</b>		
• Standard versions		1
• International version, English label inscriptions, documentation in 5 languages on CD		2
<b>Explosion protection</b>		
• None		A
• With ATEX, Type of protection:		
- "Intrinsic safety (EEx ia)"		B
- "Explosion-proof (EExd)" <sup>3)</sup>		D
- "Intrinsic safety, explosion-proof enclosure and dust explosion protection (EEx ia+ EEx d + Zone 1D/2D)" <sup>4)</sup>		R
• With FM + CSA, Type of protection:		
- "Intrinsic Safe und Explosion Proof (is + xp)" <sup>3)</sup> (Available soon)		NC
<b>Electrical connection / cable entry</b>		
• Inner thread M20 x 1.5		B
• Female thread ½-14 NPT		C
• M12 connectors (metal) <sup>5)</sup>		F
<b>Display</b>		
• Without indicator		0
• Without visible digital indicator (digital indicator concealed, setting: mA)		1
• with visible digital indication, setting: mA		6
• with customer-specific digital indication (setting as specified, Order Code "Y21" or "Y22" required)		7

Power supply units see Chap. 8 "Supplementary Components".

Included in delivery of the device:

- Brief instructions (Leporello)
- CD-ROM with detailed documentation

<sup>1)</sup> Not with temperature decoupler P00 and P10, not for process connections R02, R04, R10 and R11, and can only be ordered in conjunction with silicone oil.

<sup>2)</sup> Only possible for flange with M., N. and Q.. option.

<sup>3)</sup> Without cable gland, with blanking plug

<sup>4)</sup> With enclosed cable gland EEx ia and blanking plug

<sup>5)</sup> M12 delivered without cable socket

F) Subject to export regulations AL: 91999, ECCN: N.

# Pressure Measurement

## Transmitters for general requirements

### SITRANS P DS III for gauge/absolute pressure, with front-flush diaphragm

2

Selection and Ordering data		Order No.
<b>Pressure transmitter P for gauge and absolute pressure, front-flush diaphragm:</b>		
<b>SITRANS P DS III PA (PROFIBUS PA)</b>	F)	<b>7MF4134-</b>
<b>SITRANS P DS III FF (FOUNDATION Fieldbus)</b>	F)	<b>7MF4135-</b>
<b>Measuring cell filling</b>	<b>Measuring cell cleaning</b>	
Silicone oil	normal	1
Inert liquid	Grease-free	3
FDA compliant fill fluid		
• Neobee oil	normal	4
<b>Nominal measuring range</b>		
1 bar g	(14.5 psi g)	B
4 bar g	(58 psi g)	C
16 bar g	(232 psi g)	D
63 bar g	(914 psi g)	E
1300 mbar a <sup>1)</sup>	(18.9 psi a <sup>1)</sup> )	N
		O
		T
		U
5 bar a <sup>1)</sup>	(72.5 psi a <sup>1)</sup> )	
30 bar a <sup>1)</sup>	(435 psi a <sup>1)</sup> )	
<b>Wetted parts materials</b>		
Seal diaphragm	Connection shank	
Stainless steel	Stainless steel	A
Hastelloy <sup>2)</sup>	Stainless steel	B
<b>Process connection</b>		
• Flange version with Order Code M., N., R. or Q..		7
<b>Non-wetted parts materials</b>		
• Housing made of die-cast aluminium		0
• Housing stainless steel precision casting		3
<b>Version</b>		
• Standard versions		1
• International version, English label inscriptions, documentation in 5 languages on CD		2
<b>Explosion protection</b>		
• None		A
• With ATEX, Type of protection:		
- "Intrinsic safety (EEx ia)"		B
- "Explosion-proof (EExd) <sup>3)</sup>		D
- "Intrinsic safety, explosion-proof enclosure and dust explosion protection (EEx ia+ EEx d + Zone 1D/2D) <sup>4)</sup>		R
• With FM + CSA, Type of protection:		
- "Intrinsic Safe und Explosion Proof (is + xp) <sup>3)</sup> (Available soon)		NC
<b>Electrical connection / cable entry</b>		
• Screwed gland M20 x 1.5		B
• Screwed gland ½-14 NPT		C
• Han 7D plug (plastic housing) incl. mating connector <sup>5)</sup>		D
• M12 connectors (metal) <sup>6)</sup>		F
<b>Display</b>		
• Without indicator		0
• Without visible digital indicator (digital indicator concealed, setting: mA)	▶	1
• With visible digital display		6
• With customer-specific digital display (setting as specified, Order Code "Y21" required)		7
Included in delivery of the device:		
• Brief instructions (Leporello)		
• CD-ROM with detailed documentation		

- 1) Not with temperature decoupler P00 and P10, not for process connections R01, R02, R04, R10 and R11, and can only be ordered in conjunction with silicone oil.
- 2) Only possible for flange with M., N. and Q.. option.
- 3) Without cable gland, with blanking plug
- 4) With enclosed cable gland EEx ia and blanking plug
- 5) Not in conjunction with types of protection "Explosion-proof" and "Ex nA", "Intrinsic safety" and "Explosion-proof".
- 6) M12 delivered without cable socket
- F) Subject to export regulations AL: 9I999, ECCN: N.

# Pressure Measurement

## Transmitters for general requirements

SITRANS P DS III for gauge/absolute pressure,  
with front-flush diaphragm

2

Selection and Ordering data	Order code		
<i>Further designs</i>	HART	PA	FF
Add "-Z" to Order No. and specify Order Code.			
<b>Plug</b>			
• Angled	A32	✓	
• Han 8D (metal, gray)	A33	✓	
<b>Cable sockets for M12 connectors (metal)</b>	A50	✓	✓
<b>Rating plate inscription</b> (instead of German)			
• English	B11	✓	✓
• French	B12	✓	✓
• Spanish	B13	✓	✓
• Italian	B14	✓	✓
<b>English rating plate</b> Pressure units in inH <sub>2</sub> O and/or psi	B21	✓	✓
<b>Quality inspection certificate (factory calibration) to IEC 60770-2</b>	C11	✓	✓
<b>Inspection certificate</b> Acc. to EN 10204-3.1	C12	✓	✓
<b>Factory certificate</b> Acc. to EN 10204-2.2	C14	✓	✓
<b>PROFIsafe certificate and protocol</b>	C21		✓
<b>"Functional safety (SIL2/3)" certificate</b>	C23	✓	
<b>Ex Approval IEC Ex (EEx ia)</b> (only for transmitter 7MF4...-...-B..)	E45	✓	✓
<b>Ex Approval IEC Ex (EEx id)</b> (only for transmitter 7MF4...-...-D..)	E46	✓	✓
<b>Two coats of lacquer on casing and cover (PU on epoxy)</b>	G10	✓	✓
<b>Flanges to EN 1092-1, Form b1</b>			
• DN 25, PN 40 <sup>1)</sup>	M11	✓	✓
• DN 25, PN 100 <sup>1)</sup>	M21	✓	✓
• DN 40, PN 40	M13	✓	✓
• DN 40, PN 100	M23	✓	✓
• DN 50, PN 16	M04	✓	✓
• DN 50, PN 40	M14	✓	✓
• DN 80, PN 16	M06	✓	✓
• DN 80, PN 40	M16	✓	✓
<b>Flanges to ASME B16.5</b>			
• Stainless steel flange 1" class 150 <sup>1)</sup>	M40	✓	✓
• Stainless steel flange 1½" class 150	M41	✓	✓
• Stainless steel flange 2" class 150	M42	✓	✓
• Stainless steel flange 3" class 150	M43	✓	✓
• Stainless steel flange 4" class 150	M44	✓	✓
• Stainless steel flange 1" class 300 <sup>1)</sup>	M45	✓	✓
• Stainless steel flange 1½" class 300	M46	✓	✓
• Stainless steel flange 2" class 300	M47	✓	✓
• Stainless steel flange 3" class 300	M48	✓	✓
• Stainless steel flange 4" class 300	M49	✓	✓
<b>Threaded connector to DIN 3852-2, form A, thread to ISO 228</b>			
• G ¾"-A, front-flush <sup>2)</sup>	R01	✓	✓
• G 1"-A, front-flush <sup>2)</sup>	R02	✓	✓
• G 2"-A, front-flush <sup>2)</sup>	R04	✓	✓
<b>Tank connection<sup>3)</sup></b> Sealing is included in delivery			
• TG 52/50, PN 40	R10	✓	✓
• TG 52/150, PN 40	R11	✓	✓

Selection and Ordering data	Order code		
<i>Further designs</i>	HART	PA	FF
Add "-Z" to Order No. and specify Order Code.			
<b>Sanitary process connection according DIN 11851 (Dairy connection)</b>			
• DN 50, PN 25	N04	✓	✓
• DN 80, PN 25	N06	✓	✓
<b>Tri-Clamp connection according DIN 32676/ISO 2852</b>			
• DN 50/2", PN 16	N14	✓	✓
• DN 65/3", PN 10	N15	✓	✓
<b>Varivent connection</b> Certified to EHEDG			
• Type N = 68 for Varivent housing DN 40 ... 125 und 1½" ... 6", PN 40	N28	✓	✓
<b>Temperature decoupler up to 200 °C<sup>4)</sup></b> for version with front-flush diaphragm	P00	✓	✓
<b>Temperature decoupler up to 250 °C</b> Measuring cell filling: High-temperature oil, only in conjunction with measuring cell filling silicone oil	P10	✓	✓
<b>Bio-Control sanitary process connection</b> Certified to EHEDG			
• DN 50, PN 16	Q53	✓	✓
• DN 65, PN 16	Q54	✓	✓
<b>Sanitary process connection to DRD</b>			
• 65 mm, PN 40	M32	✓	✓
<b>SMS socket with union nut</b>			
• 2"	M67	✓	✓
• 2½"	M68	✓	✓
• 3"	M69	✓	✓
<b>SMS threaded socket</b>			
• 2"	M73	✓	✓
• 2½"	M74	✓	✓
• 3"	M75	✓	✓
<b>IDF socket with union nut ISO 2853</b>			
• 2"	M82	✓	✓
• 2½"	M83	✓	✓
• 3"	M84	✓	✓
<b>IDF threaded socket ISO 2853</b>			
• 2"	M92	✓	✓
• 2½"	M93	✓	✓
• 3"	M94	✓	✓
<b>Sanitary process connection to NEUMO Bio-Connect screw connection</b> Certified to EHEDG			
• DN 50, PN 16	Q05	✓	✓
• DN 65, PN 16	Q06	✓	✓
• DN 80, PN 16	Q07	✓	✓
• DN 100, PN 16	Q08	✓	✓
• DN 2", PN 16	Q13	✓	✓
• DN 2½", PN 16	Q14	✓	✓
• DN 3", PN 16	Q15	✓	✓
• DN 4", PN 16	Q16	✓	✓
<b>Sanitary process connection to NEUMO Bio-Connect flange connection</b> Certified to EHEDG			
• DN 50, PN 16	Q23	✓	✓
• DN 65, PN 16	Q24	✓	✓
• DN 80, PN 16	Q25	✓	✓
• DN 100, PN 16	Q26	✓	✓
• DN 2", PN 16	Q31	✓	✓
• DN 2½", PN 16	Q32	✓	✓
• DN 3", PN 16	Q33	✓	✓
• DN 4", PN 16	Q34	✓	✓

# Pressure Measurement

## Transmitters for general requirements

**SITRANS P DS III for gauge/absolute pressure, with front-flush diaphragm**

2

Selection and Ordering data	Order code		
	HART	PA	FF
<b>Further designs</b> Add "-Z" to Order No. and specify Order Code.			
<b>Sanitary process connection to NEUMO Bio-Connect clamp connection</b> Certified to EHEDG			
• DN 50, PN 16	Q39	✓	✓
• DN 65, PN 10	Q40	✓	✓
• DN 80, PN 10	Q41	✓	✓
• DN 100, PN 10	Q42	✓	✓
• DN 2½", PN 16	Q48	✓	✓
• DN 3", PN 10	Q49	✓	✓
• DN 4", PN 10	Q50	✓	✓
<b>Sanitary process connection to NEUMO Bio-Connect S flange connection</b> Certified to EHEDG			
• DN 50, PN 16	Q63	✓	✓
• DN 65, PN 10	Q64	✓	✓
• DN 80, PN 10	Q65	✓	✓
• DN 100, PN 10	Q66	✓	✓
• DN 2", PN 16	Q72	✓	✓
• DN 2½", PN 10	Q73	✓	✓
• DN 3", PN 10	Q74	✓	✓
• DN 4", PN 10	Q75	✓	✓
<b>Aseptic threaded socket to DIN 11864-1 Form A</b>			
• DN 50, PN 25	N33	✓	✓
• DN 65, PN 25	N34	✓	✓
• DN 80, PN 25	N35	✓	✓
• DN 100, PN 25	N36	✓	✓
<b>Aseptic flange with notch to DIN 11864-2 Form A</b>			
• DN 50, PN 16	N43	✓	✓
• DN 65, PN 16	N44	✓	✓
• DN 80, PN 16	N45	✓	✓
• DN 100, PN 16	N46	✓	✓
<b>Aseptic flange with groove to DIN 11864-2 Form A</b>			
• DN 50, PN 16	N43 + P11	✓	✓
• DN 65, PN 16	N44 + P11	✓	✓
• DN 80, PN 16	N45 + P11	✓	✓
• DN 100, PN 16	N46 + P11	✓	✓
<b>Aseptic clamp with groove to DIN 11864-3 Form A</b>			
• DN 50, PN 25	N53	✓	✓
• DN 65, PN 25	N54	✓	✓
• DN 80, PN 16	N55	✓	✓
• DN 100, PN 16	N56	✓	✓

1) Special seal in Viton included in the scope of delivery.

2) Lower measuring limit -100 mbar g (1.45 psi g).

3) The weldable socket can be ordered under accessories.

4) The maximum permissible temperatures of the medium depend on the respective cell fillings.

Selection and Ordering data	Order code		
	HART	PA	FF
<b>Additional data</b> Please add "-Z" to Order No. and specify Order code(s) and plain text.			
<b>Measuring range to be set</b> Specify in plain text (max. 5 characters): Y01: ... up to ... mbar, bar, kPa, MPa, psi	Y01	✓	
<b>Stainless steel tag plate (measuring point description)</b> Max. 16 characters, specify in plain text: Y15: .....	Y15	✓	✓
<b>Measuring point text</b> Max. 27 characters, specify in plain text: Y16: .....	Y16	✓	✓
<b>Entry of HART address (TAG)</b> Max. 8 characters, specify in plain text: Y17: .....	Y17	✓	
<b>Setting of pressure indicator in pressure units</b> Specify in plain text (standard setting: bar): Y21: mbar, bar, kPa, MPa, psi, ... Note: The following pressure units can be selected: bar, mbar, mm H <sub>2</sub> O <sup>1)</sup> , inH <sub>2</sub> O <sup>1)</sup> , ftH <sub>2</sub> O <sup>1)</sup> , mmHG, inHG, psi, Pa, kPa, MPa, g/cm <sup>2</sup> , kg/cm <sup>2</sup> , Torr, ATM or % <sup>2)</sup> ref. temperature 20 °C	Y21	✓	✓
<b>Preset bus address</b> possible between 1 and 126 Specify in plain text: Y25: .....	Y25		✓
Only "Y01" and "Y21" can be factory preset ✓ = available			
<b>ordering example</b> Item line: 7MF4133-1DB20-1AB7-Z B line: A22 + Y01 + Y21 C line: Y01: 1 ... 10 bar (14.5 ... 145 psi) C line: Y21: bar (psi)			

# Pressure Measurement

## Transmitters for general requirements

SITRANS P DS III for gauge/absolute pressure, with front-flush diaphragm

### Dimensional drawings

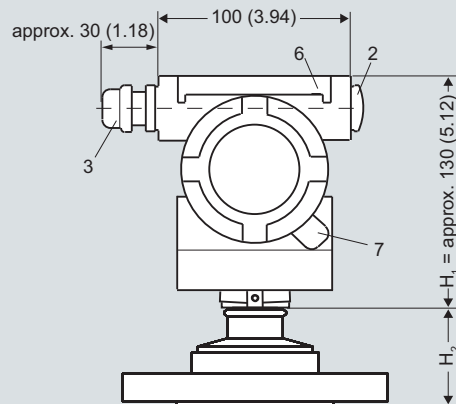
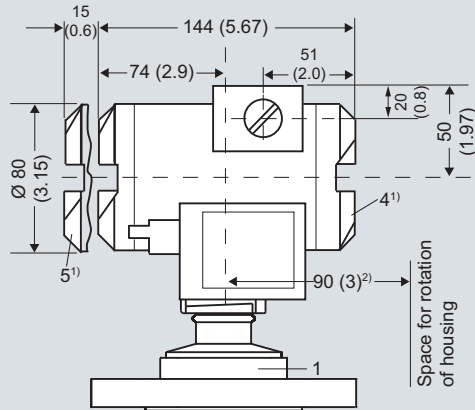

- 1 Process connection: see flange tables
- 2 Blanking plug
- 3 Electrical connection:
  - Screwed gland M20x1,5,
  - Screwed gland ½-14 NPT or
  - M12 connector
- 4 Terminal side
- 5 Electronics side, digital display (longer overall length for cover with window)
- 6 Protective cover over keys
- 7 Screw cover safety bracket (only for explosion-proof enclosure, not shown in the drawing)

- 1) Allow approx. 20 mm (0.79 inch) thread length in addition
- 2) 92 mm (3.6 inch) for minimum distance to permit rotation with indicator

SITRANS P pressure transmitters, DS III series for gauge pressure, with front-flush diaphragm, dimensions in mm (inch)

The diagram shows a SITRANS P DS III with an example of a flange. In this drawing the height is subdivided into  $H_1$  and  $H_2$ .

$H_1$  = Height of the SITRANS P300 up to a defined cross-section

$H_2$  = Height of the flange up to this defined cross-section

Only the height  $H_2$  is indicated in the dimensions of the flanges.

### Flanges as per EN and ASME

#### Flange to EN

##### EN 1092-1

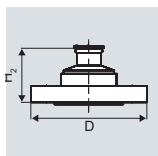

DN	PN	ØD	$H_2$
25	40	115 mm (4.5")	Approx. 52 mm (2")
25	100	140 mm (5.5")	
40	40	150 mm (5.9")	Approx. 52 mm (2")
40	100	170 mm (6.7")	
50	16	165 mm (6.5")	Approx. 52 mm (2")
50	40	165 mm (6.5")	
80	16	200 mm (7.9")	Approx. 52 mm (2")
80	40	200 mm (7.9")	

#### Flanges to ASME

##### ASME B16.5

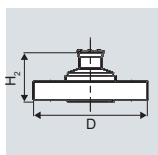

DN	Class	ØD	$H_2$
1"	150	110 mm (4.3")	Approx. 52 mm (2")
1"	300	125 mm (4.9")	
1½"	150	130 mm (5.1")	Approx. 52 mm (2")
1½"	300	155 mm (6.1")	
2"	150	150 mm (5.9")	Approx. 52 mm (2")
2"	300	165 mm (6.5")	
3"	150	190 mm (7.5")	Approx. 52 mm (2")
3"	300	210 mm (8.1")	
4"	150	230 mm (9.1")	Approx. 52 mm (2")
4"	300	255 mm (10.0")	

### F&B and pharmaceutical flanges

#### Connections to DIN

##### DIN 11851 (milk pipe union)

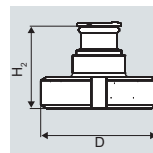

DN	PN	ØD	$H_2$
50	25	92 mm (3.6")	Approx. 52 mm (2")
80	25	127 mm (5.0")	

##### TriClamp to DIN 32676

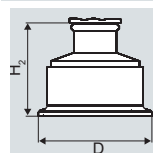

DN	PN	ØD	$H_2$
50	16	64 mm (2.5")	Approx. 52 mm (2")
65	16	91 mm (3.6")	

#### Other connections

##### Varivent connection

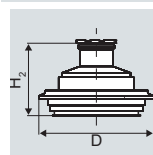

DN	PN	ØD	$H_2$
40 ... 125	40	84 mm (3.3")	Approx. 52 mm (2")

##### Biocontrol connection

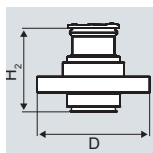

DN	PN	ØD	$H_2$
50	16	90 mm (3.5")	Approx. 52 mm (2")
65	16	120 mm (4.7")	

# Pressure Measurement

## Transmitters for general requirements

SITRANS P DS III for gauge/absolute pressure, with front-flush diaphragm

### Sanitary process connection to DRD

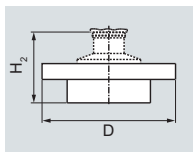

DN	PN	ØD	H <sub>2</sub>
65	40	105 mm (4.1")	Approx. 52 mm (2")

### Sanitary process screw connection to NEUMO Bio-Connect

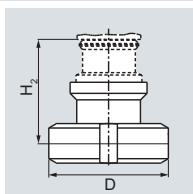

DN	PN	ØD	H <sub>2</sub>
50	16	82 mm (3.2")	Approx. 52 mm (2")
65	16	105 mm (4.1")	
80	16	115 mm (4.5")	
100	16	145 mm (5.7")	
2"	16	82 mm (3.2")	
2½"	16	105 mm (4.1")	
3"	16	105 mm (4.1")	
4"	16	145 mm (5.7")	

### Sanitary process connection to NEUMO Bio-Connect flange connection

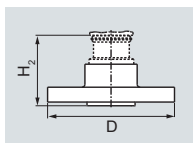

DN	PN	ØD	H <sub>2</sub>
50	16	110 mm (4.3")	Approx. 52 mm (2")
65	16	140 mm (5.5")	
80	16	150 mm (5.9")	
100	16	175 mm (6.9")	
2"	16	100 mm (3.9")	
2½"	16	110 mm (4.3")	
3"	16	140 mm (5.5")	
4"	16	175 mm (6.9")	

### Sanitary process connection to NEUMO Bio-Connect clamp connection

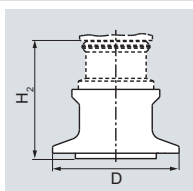

DN	PN	ØD	H <sub>2</sub>
50	16	77.4 mm (3.0")	Approx. 52 mm (2")
65	10	90.9 mm (3.6")	
80	10	106 mm (4.2")	
100	10	119 mm (4.7")	
2"	16	64 mm (2.5")	
2½"	16	77.4 mm (3.0")	
3"	10	90.9 mm (3.6")	
4"	10	779 mm (4.7")	

### Sanitary process connection to NEUMO Bio-Connect S flange connection

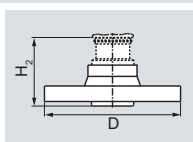

DN	PN	ØD	H <sub>2</sub>
50	16	125 mm (4.9")	Approx. 52 mm (2")
65	10	145 mm (5.7")	
80	10	155 mm (6.1")	
100	10	180 mm (7.1")	
2"	16	125 mm (4.9")	
2½"	10	135 mm (5.3")	
3"	10	145 mm (5.7")	
4"	10	180 mm (7.1")	

### Threaded connection G¾", G1" and G2" acc. to DIN 3852

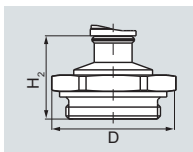

DN	PN	ØD	H <sub>2</sub>
¾"	63	37 mm (1.5")	Approx. 45 mm (1.8")
1"	63	48 mm (1.9")	approx. 47 mm (1.9")
2"	63	78 mm (3.1")	Approx. 52 mm (2")

### Tank connection TG 52/50 and TG52/150

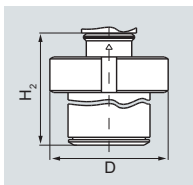

DN	PN	ØD	H <sub>2</sub>
25	40	63 mm (2.5")	Approx. 63 mm (2.5")
25	40	63 mm (2.5")	approx. 170 mm (6.7")

### SMS socket with union nut

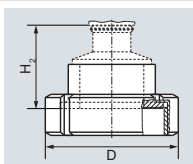

DN	PN	ØD	H <sub>2</sub>
2"	25	84 mm (3.3")	Approx. 52 mm (2.1")
2½"	25	100 mm (3.9")	
3"	25	114 mm (4.5")	

### SMS threaded socket

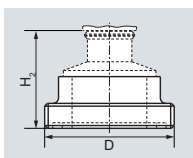

DN	PN	ØD	H <sub>2</sub>
2"	25	70 x 1/6 mm	Approx. 52 mm (2.1")
2½"	25	85 x 1/6 mm	
3"	25	98 x 1/6 mm	

### IDF socket with union nut

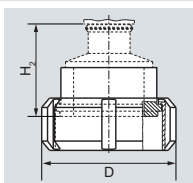

DN	PN	ØD	H <sub>2</sub>
2"	25	77 mm (3")	Approx. 52 mm (2.1")
2½"	25	91 mm (3.6")	
3"	25	106 mm (4.2")	

### IDF threaded socket

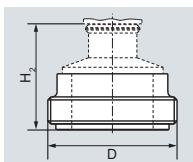

DN	PN	ØD	H <sub>2</sub>
2"	25	64 mm (2.5")	Approx. 52 mm (2.1")
2½"	25	77.5 mm (3.1")	
3"	25	91 mm (3.6")	

# Pressure Measurement

## Transmitters for general requirements

SITRANS P DS III for gauge/absolute pressure,  
with front-flush diaphragm

### Aseptic threaded socket to DIN 11864-1 Form A

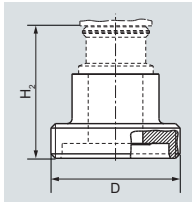

DN	PN	ØD	H <sub>2</sub>
50	25	94	Approx. 52 mm (2.1")
65	25	113	
80	25	133	
100	25	159	

### Aseptic flange with notch to DIN 11864-2 Form A

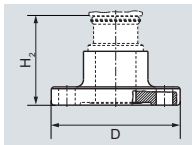

DN	PN	ØD	H <sub>2</sub>
50	16	78 x 1/6"	Approx. 52 mm (2.1")
65	16	95 x 1/6"	
80	16	110 x 1/4"	
100	16	130 x 1/4"	

### Aseptic flange with groove to DIN 11864-2 Form A

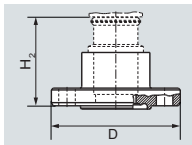

DN	PN	ØD	H <sub>2</sub>
50	16	94	Approx. 52 mm (2.1")
65	16	113	
80	16	133	
100	16	159	

### Aseptic clamp with groove to DIN 11864-3 Form A

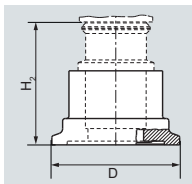

DN	PN	ØD	H <sub>2</sub>
50	25	77,5	Approx. 52 mm (2.1")
65	25	91	
80	16	106	
100	16	130	

# Pressure Measurement

## Transmitters for general requirements

**SITRANS P DS III for absolute pressure**  
(from gauge pressure series)

### Technical specifications

SITRANS P DS III series for absolute pressure (from the gauge pressure series)				
	HART		PROFIBUS PA and FOUNDATION Fieldbus	
<b>Input</b>				
Measured variable	Absolute pressure			
Spans (infinitely adjustable) or nominal measuring range and max. permissible test pressure	Span	Max. perm. test pressure	Nominal measuring range	Max. perm. test pressure
	8,3 ... 250 mbar a (0.12 ... 3.6 psi a)	6 bar a (87 psi a)	250 mbar a (3.6 psi a)	6 bar a (87 psi a)
	43 ... 1300 mbar a (0.62 ... 18.9 psi a)	10 bar a (145 psi a)	1300 mbar a (18.9 psi a)	10 bar a (145 psi a)
	160 ... 5000 mbar a (2.32 ... 72.5 psi a)	30 bar a (435 psi a)	5 bar a (72.5 psi a)	30 bar a (435 psi a)
	1 ... 30 bar a (14.5 ... 435 psi a)	100 bar a (1450 psi a)	30 bar a (435 psi a)	100 bar a (1450 psi a)
Lower measuring limit	0 mbar a (0 psi a)			
• Measuring cell with silicone oil filling				
Upper measuring limit	100 % of max. span			
<b>Output</b>				
Output signal	4 ... 20 mA		Digital PROFIBUS PA and FOUNDATION Fieldbus signal	
• Lower limit (infinitely adjustable)	3.55 mA, factory preset to 3.84 mA		-	
• Upper limit (infinitely adjustable)	23 mA, factory preset to 20.5 mA or optionally set to 22.0 mA		-	
Load				
• Without HART communication	$R_B \leq (U_H - 10.5 \text{ V})/0.023 \text{ A}$ in $\Omega$ , $U_H$ : Power supply in V		-	
• With HART communication	$R_B = 230 \dots 500 \Omega$ (SIMATIC PDM) or $R_B = 230 \dots 1100 \Omega$ (HART Communicator)		-	
Physical bus	-		IEC 61158-2	
Protection against polarity reversal	Protected against short-circuit and polarity reversal. Each connection against the other with max. supply voltage.			
<b>Measuring accuracy</b>				
Acc. to EN 60770-1				
Reference conditions (All error data refer always refer to the set span)	Increasing characteristic, start-of-scale value 0 bar, stainless steel seal diaphragm, silicone oil filling, room temperature 25 °C (77 °F) r: Span ratio (r = max. span / set span)			
Error in measurement and fixed-point setting (including hysteresis and repeatability)				
• Linear characteristic			≤ 0.1 %	
- r ≤ 10	≤ 0.1 %			
- 10 < r ≤ 30	≤ 0.2 %			
Long-term drift (temperature change ± 30 °C (± 54 °F))	≤ (0.1 · r) %/year		≤ 0.1 %/year	
Influence of ambient temperature				
• at -10 ... +60 °C (14 ... 140 °F)	≤ (0.1 · r + 0.2) %		≤ 0.3 %	
• at -40 ... -10 °C and 60 ... 85 °C (-40 ... +14 °F and 140 ... 185 °F)	≤ (0.1 · r + 0.15) %/10 K		≤ 0.25 %/10 K	
Measured Value Resolution	-		$3 \cdot 10^{-5}$ of nominal measuring range	

# Pressure Measurement

## Transmitters for general requirements

SITRANS P DS III for absolute pressure  
(from gauge pressure series)

SITRANS P DS III series for absolute pressure (from the gauge pressure series)		HART	PROFIBUS PA and FOUNDATION Fieldbus
<b>Rated conditions</b>			
Degree of protection (to EN 60529)			IP65
Temperature of medium			
• Measuring cell with silicone oil filling			-40 ... +100 °C (-40 ... +212 °F)
• Measuring cell with inert filling liquid			-20 ... +100 °C (-4 ... +212 °F)
• In conjunction with dust explosion protection			-20 ... +60 °C (-4 ... +140 °F)
Ambient conditions			
• Ambient temperature			
- Digital indicator			-30 ... +85 °C (-22 ... +185 °F)
• Storage temperature			-50 ... +85 °C (-58 ... +185 °F)
• Climatic class			
- Condensation			Relative humidity 0 ... 100 % Condensation permissible, suitable for use in the tropics
• Electromagnetic Compatibility			
- Emitted interference and interference immunity			Acc. to EN 61326 and NAMUR NE 21
<b>Design</b>			
Weight (without options)			≈ 1.5 kg (≈ 3.3 lb)
Enclosure material			Low-copper die-cast aluminum, GD-AISI 12 or stainless steel precision casting, mat. no. 1.4408
Wetted parts materials			
• Connection shank			Stainless steel, mat. no. 1.4404/316L or Hastelloy C4, mat. no. 2.4610
• Oval flange			Stainless steel, mat. no. 1.4404/316L
• Seal diaphragm			Stainless steel, mat. no. 1.4404/316L or Hastelloy C276, mat. no. 2.4819
Measuring cell filling			Silicone oil or inert filling liquid (maximum value with oxygen measurement pressure 120 bar a) (1740 psi a) at 60 °C (140 °F))
Process connection			Connection shank G $\frac{1}{2}$ B to EN 837-1, female thread $\frac{1}{2}$ -14 NPT or oval flange (PN 160 (MWP 2320 psi a) to DIN 19213 with mounting thread M10 or $\frac{7}{16}$ -20 UNF to EN 61518
Material of mounting bracket			
• Steel			Sheet-steel, Mat. No. 1.0330, chrome-plated
• Stainless steel			Sheet stainless steel, mat. no. 1.4301 (SS 304)
<b>Power supply <math>U_H</math></b>			Supplied through bus
Terminal voltage on transmitter	10.5 ... 45 V DC 10.5 ... 30 V DC in intrinsically-safe mode		-
Separate 24 V power supply necessary	-		No
Bus voltage			
• Not Ex	-		9 ... 32 V
• With intrinsically-safe operation	-		9 ... 24 V
Current consumption			
• Basic current (max.)	-		12.5 mA
• Start-up current $\leq$ basic current	-		Yes
• Max. current in event of fault	-		15.5 mA
Fault disconnection electronics (FDE) available	-		Yes

# Pressure Measurement

## Transmitters for general requirements

**SITRANS P DS III for absolute pressure  
(from gauge pressure series)**

### SITRANS P DS III series for absolute pressure (from the gauge pressure series)

#### HART

#### PROFIBUS PA and FOUNDATION Fieldbus

#### Certificates and approvals

Classification according to PED 97/23/EC

For gases of fluid group 1 and liquids of fluid group 1; complies with requirements of article 3, paragraph 3 (sound engineering practice)

Explosion protection

- Intrinsic safety "i"

PTB 99 ATEX 2122

- Marking

Ex II 1/2 G EEx ia/ib IIB/IIC T6

- Permissible ambient temperature

-40 ... +85 °C (-40 ... +185 °F) temperature class T4;  
-40 ... +70 °C (-40 ... +158 °F) temperature class T5;  
-40 ... +60 °C (-40 ... +140 °F) temperature class T6

- Connection

To certified intrinsically-safe circuits with peak values:  
 $U_i = 30 \text{ V}$ ,  $I_i = 100 \text{ mA}$ ,  
 $P_i = 750 \text{ mW}$ ;  $R_i = 300 \Omega$

FISCO supply unit:  
 $U_o = 17.5 \text{ V}$ ,  $I_o = 380 \text{ mA}$ ,  $P_o = 5.32 \text{ W}$

Linear barrier:  
 $U_o = 24 \text{ V}$ ,  $I_o = 250 \text{ mA}$ ,  $P_o = 1.2 \text{ W}$

- Effective internal inductance/capacitance

$L_i = 0.4 \text{ mH}$ ,  $C_i = 6 \text{ nF}$

$L_i = 7 \mu\text{H}$ ,  $C_i = 1.1 \text{ nF}$

- Explosion-proof "d"

PTB 99 ATEX 1160

- Marking

Ex II 1/2 G EEx d IIC T4/T6

- Permissible ambient temperature

-40 ... +85 °C (-40 ... +185 °F) temperature class T4;  
-40 ... +60 °C (-40 ... +140 °F) temperature class T6

- Connection

To circuits with values:  $U_H = 10.5 \dots 45 \text{ V DC}$

To circuits with values:  $U_H = 9 \dots 32 \text{ V DC}$

- Dust explosion protection for zone 20

PTB 01 ATEX 2055

- Marking

Ex II 1 D IP65 T 120 °C  
Ex II 1/2 D IP65 T 120 °C

- Permissible ambient temperature

-40 ... +85 °C (-40 ... +185 °F)

- Max. surface temperature

120 °C (248 °F)

- Connection

To certified intrinsically-safe circuits with peak values:  
 $U_i = 30 \text{ V}$ ,  $I_i = 100 \text{ mA}$ ,  
 $P_i = 750 \text{ mW}$ ,  $R_i = 300 \Omega$

FISCO supply unit:  
 $U_o = 17.5 \text{ V}$ ,  $I_o = 380 \text{ mA}$ ,  $P_o = 5.32 \text{ W}$

Linear barrier:  
 $U_o = 24 \text{ V}$ ,  $I_o = 250 \text{ mA}$ ,  $P_o = 1.2 \text{ W}$

- Effective internal inductance/capacitance

$L_i = 0.4 \text{ mH}$ ,  $C_i = 6 \text{ nF}$

$L_i = 7 \mu\text{H}$ ,  $C_i = 1.1 \text{ nF}$

- Dust explosion protection for zone 21/22

PTB 01 ATEX 2055

- Marking

Ex II 2 D IP65 T 120 °C

- Connection

To circuits with values:  $U_H = 10.5 \dots 45 \text{ V DC}$ ;  
 $P_{\max} = 1.2 \text{ W}$

To circuits with values:  $U_H = 9 \dots 32 \text{ V DC}$ ;  
 $P_{\max} = 1.2 \text{ W}$

- Type of protection "n" (zone 2)

TÜV 01 ATEX 1696 X

Planned

- Marking

Ex II 3 G EEx nA L IIC T4/T5/T6

- Explosion protection acc. to FM

Certificate of Compliance 3008490

- Identification (XP/DIP) or (IS); (NI)

CL I, DIV 1, GP ABCD T4...T6; CL II, DIV 1, GP EFG; CL III; CL I, ZN 0/1 AEx ia IIC T4...T6;  
CL I, DIV 2, GP ABCD T4...T6; CL II, DIV 2, GP FG; CL III

- Explosion protection to CSA

Certificate of Compliance 1153651

- Identification (XP/DIP) or (IS)

CL I, DIV 1, GP ABCD T4...T6; CL II, DIV 1, GP EFG; CL III; Ex ia IIC T4...T6; CL I, DIV 2, GP ABCD T4...T6; CL II, DIV 2, GP FG; CL III

# Pressure Measurement

## Transmitters for general requirements

SITRANS P DS III for absolute pressure  
(from gauge pressure series)

<b>HART communication</b>		<b>FOUNDATION Fieldbus communication</b>	
HART communication	230 ... 1100 Ω	Function blocks	3 function blocks analog input, 1 function block PID
Protocol	HART Version 5.x	• Analog input	Yes, linearly rising or falling characteristic
Software for computer	SIMATIC PDM	- Adaptation to customer-specific process variables	0 ... 100 s
<b>PROFIBUS PA communication</b>		- Electrical damping $T_{63}$ , adjustable	Output/input (can be locked within the device with a bridge)
Simultaneous communication with master class 2 (max.)	4	- Simulation function	parameterizable (last good value, substitute value, incorrect value)
The address can be set using	Configuration tool or local operation (standard setting address 126)	- Failure mode	Yes, one upper and lower warning limit and one alarm limit respectively
Cyclic data usage		- Limit monitoring	Yes
• Output byte	5 (one measured value) or 10 (two measured values)	- Square-rooted characteristic for flow measurement	Standard FF function block
• Input byte	0, 1, or 2 (register operating mode and reset function for metering)	• PID	1 resource block
Internal preprocessing		• Physical block	1 transducer block Pressure with calibration, 1 transducer block LCD
Device profile	PROFIBUS PA Profile for Process Control Devices Version 3.0, Class B	Transducer blocks	
Function blocks	2	• Pressure transducer block	
• Analog input		- Can be calibrated by applying two pressures	Yes
- Adaptation to customer-specific process variables	Yes, linearly rising or falling characteristic	- Monitoring of sensor limits	Yes
- Electrical damping $T_{63}$ , adjustable	0 to 100 s	- Simulation function: Measured pressure value, sensor temperature and electronics temperature	Constant value or over parameterizable ramp function
- Simulation function	Input /Output		
- Failure mode	parameterizable (last good value, substitute value, incorrect value)		
- Limit monitoring	Yes, one upper and lower warning limit and one alarm limit respectively		
• Register (totalizer)	Can be reset, preset, optional direction of counting, simulation function of register output		
- Failure mode	parameterizable (summation with last good value, continuous summation, summation with incorrect value)		
- Limit monitoring	One upper and lower warning limit and one alarm limit respectively		
• Physical block	1		
Transducer blocks	2		
• Pressure transducer block			
- Can be calibrated by applying two pressures	Yes		
- Monitoring of sensor limits	Yes		
- Specification of a container characteristic with	Max. 30 nodes		
- Square-rooted characteristic for flow measurement	Yes		
- Gradual volume suppression and implementation point of square-root extraction	Parameterizable		
- Simulation function for measured pressure value and sensor temperature	Constant value or over parameterizable ramp function		

# Pressure Measurement

## Transmitters for general requirements

### SITRANS P DS III for absolute pressure (from gauge pressure series)

2

Selection and Ordering data		Order No.
<b>Pressure transmitters for absolute pressure aus series pressure, SITRANS P DS III HART</b>		F) 7MF4233 -
<b>Measuring cell filling</b>	<b>Measuring cell cleaning</b>	
Silicone oil	normal	1
Inert liquid <sup>1)</sup>	Grease-free	3
<b>Measuring span</b>		
8.3 ... 250 mbar a	(0.12 ... 3.63 psi a)	D
43 ... 1300 mbar a	(0.62 ... 18.9 psi a)	F
0.16 ... 5 bar a	(2.32 ... 72.5 psi a)	G
1 ... 30 bar a	(14.5 ... 435 psi a)	H
<b>Wetted parts materials</b>		
Seal diaphragm	Process connection	
Stainless steel	Stainless steel	F) A
Hastelloy	Stainless steel	F) B
Hastelloy	Hastelloy	F) C
Version for diaphragm seal <sup>2)3)4)</sup>		Y
<b>Process connection</b>		
• Connection shank G $\frac{1}{2}$ B to EN 837-1		0
• Female thread $\frac{1}{2}$ -14 NPT		1
• Stainless steel oval flange		
- Mounting thread $\frac{7}{16}$ -20 UNF to EN 61518		2
- Mounting thread M10 to DIN 19213		3
- Mounting thread M12 to DIN 19213		4
• Male thread M20 x 1.5		5
• Male thread $\frac{1}{2}$ -14 NPT		6
<b>Non-wetted parts materials</b>		
• Housing made of die-cast aluminium		0
• Housing stainless steel precision casting <sup>5)</sup>		3
<b>Version</b>		
• Standard versions		1
• International version, English label inscriptions, documentation in 5 languages on CD		2
<b>Explosion protection</b>		
• None		A
• With ATEX, Type of protection:		
- "Intrinsic safety (EEx ia)"		B
- "Explosion-proof (EEx d)" <sup>6)</sup>		D
- "Intrinsic safety and flameproof enclosure" (EEx ia + EEx d)" <sup>7)</sup>		P
- "Ex nA/nL (Zone 2)"		E
- "Intrinsic safety, explosion-proof enclosure and dust explosion protection (EEx ia+ EEx d + Zone 1D/2D)" <sup>7)</sup>		R
• With FM + CSA, Type of protection:		
- "Intrinsic Safe und Explosion Proof (is + xp)" <sup>6)</sup>		NC
<b>Electrical connection / cable entry</b>		
• Screwed gland Pg 13.5 <sup>8)</sup>		A
• Screwed gland M20x1.5		B
• Screwed gland $\frac{1}{2}$ -14 NPT		C
• Han 7D plug (plastic housing) incl. mating connector <sup>8)</sup>		D
• M12 connectors (metal) <sup>9)</sup>		F

Selection and Ordering data		Order No.
<b>Pressure transmitters for absolute pressure aus series pressure, SITRANS P DS III HART</b>		F) 7MF4233 -
<b>Display</b>		
• Without indicator		0
• Without visible digital indicator(digital indicator concealed, setting: mA)		1
• With visible digital indicator		6
• with customer-specific digital indicator (setting as specified, Order Code "Y21" or "Y22" required)		7
Power supply units see Chap. 8 "Supplementary Components".		
Included in delivery of the device:		
• Brief instructions (Leporello)		
• CD-ROM with detailed documentation		
1) For oxygen application, add Order code E10.		
2) Version 7MF4233-1DY... only up to max. span 200 mbar a (2.9 psi a).		
3) When the manufacture's certificate (calibration certificate) has to be ordered for transmitters with diaphragm seals according to IEC 60770-2, it is recommended only to order this certificate exclusively with the diaphragm seals. The measuring accuracy of the total combination is certified here.If the acceptance test certificate 3.1.is ordered for the transmitter with mounted diaphragm seals this certificate must also be ordered with the respective remote seals.		
4) If the acceptance test certificate 3.1.is ordered for the transmitter with mounted diaphragm seals this certificate must also be ordered with the respective remote seals.		
5) Not in conjunction with Electrical connection "Screwed gland Pg 13.5" and "Han7D plug".		
6) Without cable gland, with blanking plug.		
7) With enclosed cable gland EEx ia and blanking plug.		
8) Not in conjunction with types of protection "Explosion-proof" and "Ex nA", "Intrinsic safety" and "Explosion-proof".		
9) M12 delivered without cable socket		
F) Subject to export regulations AL: 91999, ECCN: N.		

# Pressure Measurement

## Transmitters for general requirements

SITRANS P DS III for absolute pressure  
(from gauge pressure series)

Selection and Ordering data		Order No.
<b>For absolute pressure (from the gauge pressure series)</b>		
SITRANS P DS III PA (PROFIBUS PA)	F)	7 MF 4 2 3 4 -
SITRANS P DS III FF (FOUNDATION Fieldbus)	F)	7 MF 4 2 3 5 -
<b>Measuring cell filling</b>		
Silicone oil	normal	1
Inert liquid <sup>1)</sup>	Grease-free	3
<b>Nominal measuring range</b>		
250 mbar a	(3.63 psi a)	D
1300 mbar a	(18.9 psi a)	F
5 bar a	(72.5 psi a)	G
30 bar a	(435 psi a)	H
<b>Wetted parts materials</b>		
Seal diaphragm	Process connection	
Stainless steel	Stainless steel	F) A
Hastelloy	Stainless steel	F) B
Hastelloy	Hastelloy	F) C
Version as diaphragm seal <sup>2) 3) 4)</sup>		Y
<b>Process connection</b>		
• Connection shank G½B to EN 837-1		0
• Female thread ½-14 NPT		1
• Stainless steel oval flange		
- Mounting thread 7/16-20 UNF to EN 61518		2
- Mounting thread M10 to DIN 19213		3
- Mounting thread M12 to DIN 19213		4
• Male thread M20 x 1.5		5
• Male thread ½ -14 NPT		6
<b>Non-wetted parts materials</b>		
• Housing made of die-cast aluminium		0
• Housing stainless steel precision casting		3
<b>Version</b>		
• Standard versions		1
• International version, English label inscriptions, documentation in 5 languages on CD		2
<b>Explosion protection</b>		
• None		A
• With ATEX, Type of protection:		
- "Intrinsic safety (EEx ia)"		B
- "Explosion-proof (EEx d) <sup>5)</sup> "		D
- "Intrinsic safety and flameproof enclosure" (EEx ia + EEx d) <sup>6)</sup>		P
- "Ex nA/nL"		E
- "Intrinsic safety, explosion-proof enclosure and dust explosion protection (EEx ia + EEx d + Zone 1D/2D) <sup>6)</sup> " (not for DS III FF)		R
• With FM + CSA, Type of protection:		
- "Intrinsic Safe und Explosion Proof (is + xp) <sup>5)</sup> "		NC
<b>Electrical connection / cable entry</b>		
• Screwed gland M20 x 1.5		B
• Screwed gland ½-14 NPT		C
• M12 connectors (metal) <sup>7)</sup>		F

Selection and Ordering data		Order No.
<b>For absolute pressure (from the gauge pressure series)</b>		
SITRANS P DS III PA (PROFIBUS PA)	F)	7 MF 4 2 3 4 -
SITRANS P DS III FF (FOUNDATION Fieldbus)	F)	7 MF 4 2 3 5 -
<b>Display</b>		
• Without indicator		0
• Without visible digital indicator (digital indicator concealed, setting: mA)		1
• With visible digital indicator		6
• with customer-specific digital indicator (setting as specified, Order Code "Y21" or "Y22" required)		7
Included in delivery of the device:		
• Brief instructions (Leporello)		
• CD-ROM with detailed documentation		
1) For oxygen application, add Order code E10.		
2) Version 7MF4233-1DY... only up to max. span 200 mbar a (2.9 psi a).		
3) When the manufacturer's certificate (calibration certificate) has to be ordered for transmitters with diaphragm seals according to IEC 60770-2, it is recommended only to order this certificate exclusively with the diaphragm seals. The measuring accuracy of the <u>total</u> combination is certified here.		
4) If the acceptance test certificate 3.1 is ordered for the transmitter with mounted diaphragm seals this certificate must also be ordered with the respective remote seals.		
5) Without cable gland, with blanking plug.		
6) With enclosed cable gland EEx ia and blanking plug.		
7) M12 delivered without cable socket		
F) Subject to export regulations AL: 91999, ECCN: N.		

# Pressure Measurement

## Transmitters for general requirements

### SITRANS P DS III for absolute pressure (from gauge pressure series)

2

Selection and Ordering data	Order code		
<i>Further designs</i>	HART	PA	FF
Add "-Z" to Order No. and specify Order Code.			
<b>Pressure transmitter with mounting bracket (2 shackles, 4 nuts, 4 U-plates, 1 angle) made of:</b>			
• Steel	A01	✓	✓
• Stainless steel	A02	✓	✓
<b>plug</b>			
• Han 7D (metal, gray)	A30	✓	
• Han 8U (instead of Han 7D)	A31	✓	
• Angled	A32	✓	
• Han 8D (metal, gray)	A33	✓	
<b>Cable sockets for M12 connectors (metal)</b>	A50	✓	✓
<b>Rating plate inscription</b> (instead of German)			
• English	B11	✓	✓
• French	B12	✓	✓
• Spanish	B13	✓	✓
• Italian	B14	✓	✓
<b>English rating plate</b>	B21	✓	✓
Pressure units in inH <sub>2</sub> O and/or psi			
<b>Quality inspection certificate (factory calibration) to IEC 60770-2<sup>1)</sup></b>	C11	✓	✓
<b>Inspection certificate<sup>2)</sup></b> Acc. to EN 10204-3.1	C12	✓	✓
<b>Factory certificate</b> Acc. to EN 10204-2.2	C14	✓	✓
<b>"Functional safety (SIL2)" certificate</b>	C20	✓	
<b>PROFIsafe certificate and protocol</b>	C21		✓
<b>"Functional safety (SIL2/3)" certificate</b>	C23	✓	
<b>Setting of upper limit of output signal to 22.0 mA</b>	D05	✓	
<b>Manufacturer's declaration acc. to NACE</b>	D07	✓	✓
<b>Degree of protection IP68</b> (only for M20 x 1.5 and ½-14 NPT)	D12	✓	✓
<b>Supplied with oval flange</b> (1 item), PTFE packing and screws in thread of oval flange	D37	✓	✓
<b>Use in or on zone 1D/2D</b> (only together with type of protection "Intrinsic safety (EEx ia)")	E01	✓	✓
<b>Oxygen application</b> (In the case of oxygen measurement and inert liquid max. 120 bar a (1740 psi a) at 60°C (140 °F))	E10	✓	✓
<b>Explosion-proof "Intrinsic safety" to INMETRO (Brazil)</b> (only for transmitter 7MF4...-.....-B..)	E25	✓	✓
<b>Ex Approval IEC Ex (EEx ia)</b> (only for transmitter 7MF4...-.....-B..)	E45	✓	✓
<b>Ex Approval IEC Ex (EEx id)</b> (only for transmitter 7MF4...-.....-D..)	E46	✓	✓
<b>Explosion-proof "Intrinsic safety" to NEPSI (China)</b> (only for transmitter 7MF4...-.....-B..)	E55	✓	✓

Selection and Ordering data	Order code		
<i>Further designs</i>	HART	PA	FF
Add "-Z" to Order No. and specify Order Code.			
<b>Explosion protection "Explosion-proof" to NEPSI (China)</b> (only for transmitter 7MF4...-.....-D..)	E56	✓	✓
<b>Explosion-proof "Zone 2" to NEPSI (China)</b> (only for transmitter 7MF4...-.....-E..)	E57	✓	✓
<b>Two coats of lacquer on casing and cover (PU on epoxy)</b>	G10	✓	✓
<b>Additional data</b>			
Please add "-Z" to Order No. and specify Order code(s) and plain text.			
<b>Measuring range to be set</b> Specify in plain text (max. 5 characters): Y01: ... up to ... mbar, bar, kPa, MPa, psi	Y01	✓	
<b>Stainless steel tag plate (measuring point description)</b> Max. 16 characters, specify in plain text: Y15: .....	Y15	✓	✓
<b>Measuring point text</b> Max. 27 characters, specify in plain text: Y16: .....	Y16	✓	✓
<b>Entry of HART address (TAG)</b> Max. 8 characters, specify in plain text: Y17: .....	Y17	✓	
<b>Setting of pressure indication in pressure units</b> Specify in plain text (standard setting: bar): Y21: mbar, bar, kPa, MPa, psi, ... Note: The following pressure units can be selected: bar, mbar, mm H <sub>2</sub> O <sup>1)</sup> , inH <sub>2</sub> O <sup>1)</sup> , ftH <sub>2</sub> O <sup>1)</sup> , mmHG, inHG, psi, Pa, kPa, MPa, g/cm <sup>2</sup> , kg/cm <sup>2</sup> , Torr, ATM or % ) ref. temperature 20 °C	Y21	✓	✓
<b>Setting of pressure indication in non-pressure units<sup>3)</sup></b> Specify in plain text: Y22: .... up to .... l/min, m <sup>3</sup> /h, m, USgpm, ... (specification of measuring range in pressure units "Y01" is essential, unit with max. 5 characters)	Y22 + Y01	✓	
<b>Preset bus address</b> possible between 1 and 126 Specify in plain text: Y25: .....	Y25		✓
Factory mounting of valve manifolds, see accessories.			
Only "Y01", "Y21", "Y22", "Y25" and "D05" can be factory preset			
✓ = available			
<sup>1)</sup> When the manufacture's certificate (calibration certificate) has to be ordered for transmitters with diaphragm seals according to IEC 60770-2, it is recommended only to order this certificate exclusively with the diaphragm seals. The measuring accuracy of the total combination is certified here.			
<sup>2)</sup> If the acceptance test certificate 3.1 is ordered for the transmitter with mounted diaphragm seals this certificate must also be ordered with the respective remote seals.			
<sup>3)</sup> Preset values can only be changed over SIMATIC PDM.			

# Pressure Measurement

## Transmitters for general requirements

SITRANS P DS III for absolute pressure  
(from gauge pressure series)

### Dimensional drawings

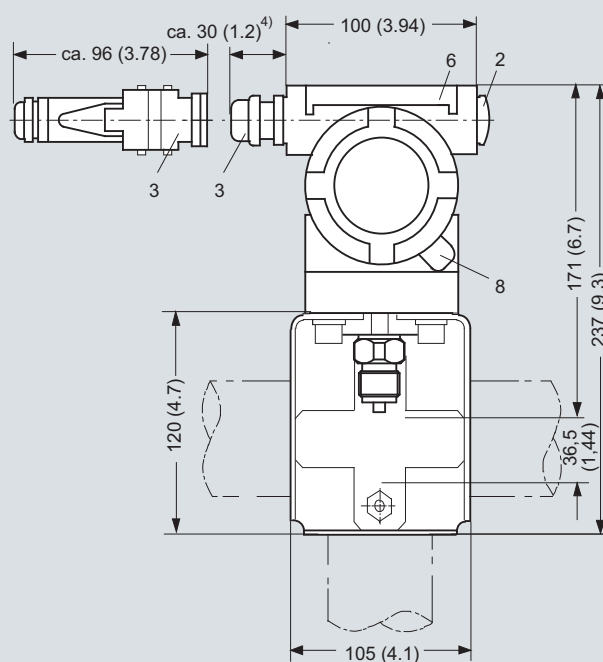
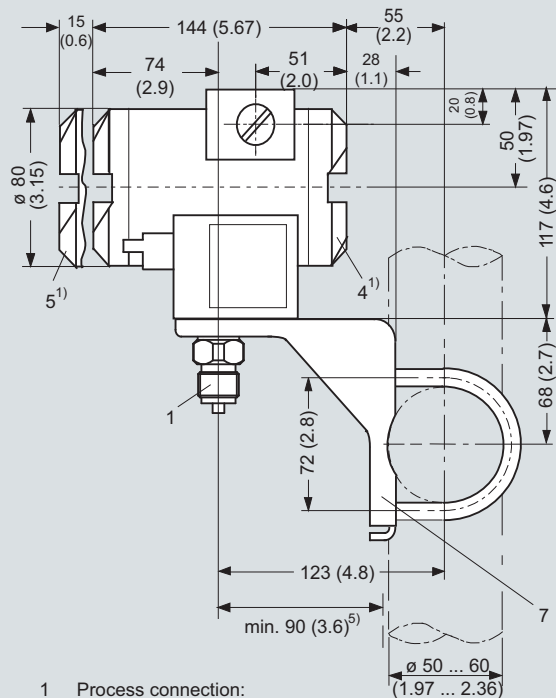

- 1 Process connection:
  - 1/2-14 NPT,
  - Connection shank G1/2B or
  - Oval flange
- 2 Blanking plug
- 3 Electrical connection:
  - Screwed gland Pg 13,5 (adapter)<sup>2) 3)</sup>, only DS III HART,
  - Screwed gland M20x1,5<sup>3)</sup>,
  - Screwed gland 1/2-14 NPT,
  - Han 7D/Han 8D<sup>2) 3)</sup> plug, only DS III HART, or
  - M12 connector
- 4 Terminal side
- 5 Electronic side, digital display (longer overall length for cover with window)
- 6 Protective cover over keys
- 7 Mounting bracket (option)
- 8 Screw cover - safety bracket (only for type of protection "Explosion-proof enclosure", not shown in the drawing)

- 1) Allow approx. 20 mm (0.79 inch) thread length to permit unscrewing
- 2) Not with type of protection "Explosion-proof enclosure"
- 3) Not with type of protection "FM + CSA" [is + xp]
- 4) For Pg 13,5 with adapter approx. 45 mm (1.77 inch)
- 5) Minimum distance for rotating

SITRANS P DS III pressure transmitters for absolute pressure, from the pressure series, dimensions in mm (inch)

# Pressure Measurement

## Transmitters for general requirements

**SITRANS P DS III for absolute pressure**  
(from differential pressure series)

### Technical specifications

SITRANS P, DS III for absolute pressure (from the differential pressure series)				
	HART		PROFIBUS PA and FOUNDATION Fieldbus	
<b>Input</b>				
Measured variable	Absolute pressure			
Spans (infinitely adjustable) or nominal measuring range and max. permissible operating pressure	Span (infinitely adjustable)	Maximum operating pressure	Nominal measuring range	Maximum operating pressure
	8.3 ... 250 mbar a (0.12 ... 3.6 psi a)	32 bar a (464 psi a)	250 mbar a (3.6 psi a)	32 bar a (464 psi a)
	43 ... 1300 mbar a (0.62 ... 18.9 psi a)	32 bar a (464 psi a)	1300 bar a (18.9 psi a)	32 bar a (464 psi a)
	160 ... 5000 mbar a (2.32 ... 72.5 psi a)	32 bar a (464 psi a)	5 bar a (72.5 psi a)	32 bar a (464 psi a)
	1 ... 30 bar a (14.5 ... 435 psi a)	160 bar a (2320 psi a)	30 bar a (435 psi a)	160 bar a (2320 psi a)
	5.3 ... 100 bar a (76.9 ... 1450 psi a)	160 bar a (2320 psi a) (for connection thread M10 and 7/16-20 UNF in the process flanges)	100 bar a (1450 psi a)	160 bar a (2320 psi a) (for connection thread M10 and 7/16-20 UNF in the process flanges)
Lower measuring limit	0 mbar a (0 psi a)			
• Measuring cell with silicone oil filling				
Upper measuring limit	100 % of max. span			
<b>Output</b>				
Output signal	4 ... 20 mA		Digital PROFIBUS PA and FOUNDATION Fieldbus signal	
• Lower limit (infinitely adjustable)	3.55 mA, factory preset to 3.84 mA		-	
• Upper limit (infinitely adjustable)	23 mA, factory preset to 20.5 mA or optionally set to 22.0 mA		-	
Load				
• Without HART communication	$R_B \leq (U_H - 10.5 \text{ V})/0.023 \text{ A}$ in $\Omega$ , $U_H$ : Power supply in V		-	
• With HART communication	$R_B = 230 \dots 500 \Omega$ (SIMATIC PDM) or $R_B = 230 \dots 1100 \Omega$ (HART Communicator)		-	
Physical bus	-		IEC 61158-2	
Protection against polarity reversal	Protected against short-circuit and polarity reversal. Each connection against the other with max. supply voltage.			
<b>Measuring accuracy</b>				
Acc. to EN 60770-1				
Reference conditions (All error data refer always refer to the set span)	Increasing characteristic, start-of-scale value 0 bar, stainless steel seal diaphragm, silicone oil filling, room temperature 25 °C (77 °F) r: Span ratio (r = max. span / set span)			
Error in measurement and fixed-point setting (including hysteresis and repeatability)				
• Linear characteristic			≤ 0.1 %	
- r ≤ 10	≤ 0.1 %			
- 10 < r ≤ 30	≤ 0.2 %			
Long-term drift (temperature change ± 30 °C (± 54 °F))	≤ (0.1 · r) %/year		≤ 0.1 %/year	
Influence of ambient temperature				
• at -10 ... +60 °C (14 ... 140 °F)	≤ (0.1 · r + 0.2) %		≤ 0.3 %	
• at -40 ... -10 °C and 60 ... 85 °C (-40 ... +14 °F and 140 ... 185 °F)	≤ (0.1 · r + 0.15) %/10 K		≤ 0.25 %/10 K	
Measured Value Resolution	-		$3 \cdot 10^{-5}$ of nominal measuring range	

# Pressure Measurement

## Transmitters for general requirements

SITRANS P DS III for absolute pressure  
(from differential pressure series)

SITRANS P, DS III for absolute pressure (from the differential pressure series)		
	HART	PROFIBUS PA and FOUNDATION Fieldbus
<b>Rated conditions</b>		
Degree of protection (to EN 60529)		IP65
Temperature of medium		
• Measuring cell with silicone oil filling		-40 ... +100 °C (-40 ... +212 °F)
• Measuring cell with inert filling liquid		-20 ... +100 °C (-4 ... +212 °F)
• In conjunction with dust explosion protection		-20 ... +60 °C (-4 ... +140 °F)
Ambient conditions		
• Ambient temperature		
- Digital indicator		-30 ... +85 °C (-22 ... +185 °F)
• Storage temperature		-50 ... +85 °C (-58 ... +185 °F)
• Climatic class		
- Condensation		Relative humidity 0 ... 100 % Condensation permissible, suitable for use in the tropics
• Electromagnetic Compatibility		
- Emitted interference and interference immunity		Acc. to EN 61326 and NAMUR NE 21
<b>Design</b>		
Weight (without options)		≈ 4.5 kg (≈ 9.9 lb)
Enclosure material		Low-copper die-cast aluminum, GD-AISI12 or stainless steel precision casting, mat. no. 1.4408
Wetted parts materials		
• Seal diaphragm		Stainless steel, mat. no. 1.4404/316L or Hastelloy C276, mat. no. 2.4819, Monel, mat. no. 2.4360, tantalum or gold
• Process flanges and sealing screw		Stainless steel, mat. no. 1.4408, Hastelloy C4, mat. no. 2.4610 or Monel, mat. no. 2.4360
• O-Ring		FPM (Viton) or optionally: PTFE, FEP, FEPM and NBR
Measuring cell filling		Silicone oil or inert filling liquid (maximum value with oxygen measurement pressure 120 bar a) (1740 psi a) at 60 °C (140 °F))
Process connection		1/4-18 NPT and flange connection with mounting thread M10 to DIN 19213 or 7/16-20 UNF to EN 61518
Material of mounting bracket		
• Steel		Sheet-steel, Mat. No. 1.0330, chrome-plated
• Stainless steel		Sheet stainless steel, mat. no. 1.4301 (SS 304)
<b>Power supply <math>U_H</math></b>		
Terminal voltage on transmitter	10.5 ... 45 V DC 10.5 ... 30 V DC in intrinsically-safe mode	Supplied through bus -
Separate 24 V power supply necessary	-	No
Bus voltage		
• Not Ex	-	9 ... 32 V
• With intrinsically-safe operation	-	9 ... 24 V
Current consumption		
• Basic current (max.)	-	12.5 mA
• Start-up current ≤ basic current	-	Yes
• Max. current in event of fault	-	15.5 mA
Fault disconnection electronics (FDE) available	-	Yes

# Pressure Measurement

## Transmitters for general requirements

**SITRANS P DS III for absolute pressure  
(from differential pressure series)**

### SITRANS P, DS III for absolute pressure (from the differential pressure series)

#### HART

#### PROFIBUS PA and FOUNDATION Fieldbus

#### Certificates and approvals

Classification according to PED 97/23/EC

For gases of fluid group 1 and liquids of fluid group 1; complies with requirements of article 3, paragraph 3 (sound engineering practice)

Explosion protection

- Intrinsic safety "i"

PTB 99 ATEX 2122

- Marking

Ex II 1/2 G EEx ia/ib IIB/IIC T6

- Permissible ambient temperature

-40 ... +85 °C (-40 ... +185 °F) temperature class T4;  
-40 ... +70 °C (-40 ... +158 °F) temperature class T5;  
-40 ... +60 °C (-40 ... +140 °F) temperature class T6

- Connection

To certified intrinsically-safe circuits with peak values:  
 $U_i = 30 \text{ V}$ ,  $I_i = 100 \text{ mA}$ ,  
 $P_i = 750 \text{ mW}$ ;  $R_i = 300 \Omega$

FISCO supply unit:  
 $U_o = 17.5 \text{ V}$ ,  $I_o = 380 \text{ mA}$ ,  $P_o = 5.32 \text{ W}$

Linear barrier:  
 $U_o = 24 \text{ V}$ ,  $I_o = 250 \text{ mA}$ ,  $P_o = 1.2 \text{ W}$

- Effective internal inductance/capacitance

$L_i = 0.4 \text{ mH}$ ,  $C_i = 6 \text{ nF}$

$L_i = 7 \mu\text{H}$ ,  $C_i = 1.1 \text{ nF}$

- Explosion-proof "d"

PTB 99 ATEX 1160

- Marking

Ex II 1/2 G EEx d IIC T4/T6

- Permissible ambient temperature

-40 ... +85 °C (-40 ... +185 °F) temperature class T4;  
-40 ... +60 °C (-40 ... +140 °F) temperature class T6

- Connection

To circuits with values:  $U_H = 10.5 \dots 45 \text{ V DC}$

To circuits with values:  $U_H = 9 \dots 32 \text{ V DC}$

- Dust explosion protection for zone 20

PTB 01 ATEX 2055

- Marking

Ex II 1 D IP65 T 120 °C  
Ex II 1/2 D IP65 T 120 °C

- Permissible ambient temperature

-40 ... +85 °C (-40 ... +185 °F)

- Max. surface temperature

120 °C (248 °F)

- Connection

To certified intrinsically-safe circuits with peak values:  
 $U_i = 30 \text{ V}$ ,  $I_i = 100 \text{ mA}$ ,  
 $P_i = 750 \text{ mW}$ ,  $R_i = 300 \Omega$

FISCO supply unit:  
 $U_o = 17.5 \text{ V}$ ,  $I_o = 380 \text{ mA}$ ,  $P_o = 5.32 \text{ W}$

Linear barrier:  
 $U_o = 24 \text{ V}$ ,  $I_o = 250 \text{ mA}$ ,  $P_o = 1.2 \text{ W}$

- Effective internal inductance/capacitance

$L_i = 0.4 \text{ mH}$ ,  $C_i = 6 \text{ nF}$

$L_i = 7 \mu\text{H}$ ,  $C_i = 1.1 \text{ nF}$

- Dust explosion protection for zone 21/22

PTB 01 ATEX 2055

- Marking

Ex II 2 D IP65 T 120 °C

- Connection

To circuits with values:  $U_H = 10.5 \dots 45 \text{ V DC}$ ;  
 $P_{\max} = 1.2 \text{ W}$

To circuits with values:  $U_H = 9 \dots 32 \text{ V DC}$ ;  
 $P_{\max} = 1.2 \text{ W}$

- Type of protection "n" (zone 2)

TÜV 01 ATEX 1696 X

Planned

- Marking

Ex II 3 G EEx nA L IIC T4/T5/T6

- Explosion protection acc. to FM

Certificate of Compliance 3008490

- Identification (XP/DIP) or (IS); (NI)

CL I, DIV 1, GP ABCD T4...T6; CL II, DIV 1, GP EFG; CL III; CL I, ZN 0/1 AEx ia IIC T4...T6;  
CL I, DIV 2, GP ABCD T4...T6; CL II, DIV 2, GP FG; CL III

- Explosion protection to CSA

Certificate of Compliance 1153651

- Identification (XP/DIP) or (IS)

CL I, DIV 1, GP ABCD T4...T6; CL II, DIV 1, GP EFG; CL III; Ex ia IIC T4...T6; CL I, DIV 2, GP ABCD T4...T6; CL II, DIV 2, GP FG; CL III

# Pressure Measurement

## Transmitters for general requirements

SITRANS P DS III for absolute pressure  
(from differential pressure series)

<b>HART communication</b>	
HART communication	230 ... 1100 Ω
Protocol	HART Version 5.x
Software for computer	SIMATIC PDM
<b>PROFIBUS PA communication</b>	
Simultaneous communication with master class 2 (max.)	4
The address can be set using	Configuration tool or local operation (standard setting address 126)
Cyclic data usage	
• Output byte	5 (one measured value) or 10 (two measured values)
• Input byte	0, 1, or 2 (register operating mode and reset function for metering)
Internal preprocessing	
Device profile	PROFIBUS PA Profile for Process Control Devices Version 3.0, Class B
Function blocks	2
• Analog input	
- Adaptation to customer-specific process variables	Yes, linearly rising or falling characteristic
- Electrical damping $T_{63}$ , adjustable	0 ... 100 s
- Simulation function	Input /Output
- Failure mode	parameterizable (last good value, substitute value, incorrect value)
- Limit monitoring	Yes, one upper and lower warning limit and one alarm limit respectively
• Register (totalizer)	Can be reset, preset, optional direction of counting, simulation function of register output
- Failure mode	parameterizable (summation with last good value, continuous summation, summation with incorrect value)
- Limit monitoring	One upper and lower warning limit and one alarm limit respectively
• Physical block	1
Transducer blocks	2
• Pressure transducer block	
- Can be calibrated by applying two pressures	Yes
- Monitoring of sensor limits	Yes
- Specification of a container characteristic with	Max. 30 nodes
- Square-rooted characteristic for flow measurement	Yes
- Gradual volume suppression and implementation point of square-root extraction	Parameterizable
- Simulation function for measured pressure value and sensor temperature	Constant value or over parameterizable ramp function

### **FOUNDATION Fieldbus communication**

Function blocks	3 function blocks analog input, 1 function block PID
• Analog input	
- Adaptation to customer-specific process variables	Yes, linearly rising or falling characteristic
- Electrical damping $T_{63}$ , adjustable	0 to 100 s
- Simulation function	Output/input (can be locked within the device with a bridge)
- Failure mode	parameterizable (last good value, substitute value, incorrect value)
- Limit monitoring	Yes, one upper and lower warning limit and one alarm limit respectively
- Square-rooted characteristic for flow measurement	Yes
• PID	Standard FF function block
• Physical block	1 resource block
Transducer blocks	1 transducer block Pressure with calibration, 1 transducer block LCD
• Pressure transducer block	
- Can be calibrated by applying two pressures	Yes
- Monitoring of sensor limits	Yes
- Simulation function: Measured pressure value, sensor temperature and electronics temperature	Constant value or over parameterizable ramp function

# Pressure Measurement

## Transmitters for general requirements

### SITRANS P DS III for absolute pressure (from differential pressure series)

2

Selection and Ordering data		Order No.	
<b>Pressure transmitters for absolute pressure from differential pressure series, SITRANS P DS III HART</b>		F)	7MF4333 -
<b>Measuring cell filling</b>	<b>Measuring cell cleaning</b>		
Silicone oil	normal	1	
Inert liquid <sup>1)</sup>	Grease-free	3	
<b>Measuring span</b>			
8.3 ... 250 mbar a	(0.12 ... 3.63 psi a)	E)	D
43 ... 1300 mbar a	(0.62 ... 18.9 psi a)	E)	F
0.16 ... 5 bar a	(2.32 ... 72.5 psi a)	E)	G
1 ... 30 bar a	(14.5 ... 435 psi a)		H
5.3 ... 100 bar a	(76.9 ... 1450 psi a)		KE
<b>Wetted parts materials</b>			
Seal diaphragm	Parts of measuring cell		
Stainless steel	Stainless steel		A
Hastelloy	Stainless steel		B
Hastelloy	Hastelloy		C
Tantalum	Tantalum		E
Monel	Monel	E)	H
Gold	Gold		L
Version for diaphragm seal <sup>2)3)4)</sup>			Y
<b>Process connection</b>			
Female thread 1/4-18 NPT with flange connection			
• Sealing screw opposite process connection			
- Mounting thread 7/16"-20 UNF to EN 61518		2	
- Mounting thread M10 to DIN 19213 (only for replacement requirement)		0	
• Vent on side of process flange <sup>5)</sup>			
- Mounting thread 7/16"-20 UNF to EN 61518		6	
- Mounting thread M10 to DIN 19213 (only for replacement requirement)		4	
<b>Non-wetted parts materials</b>			
process flange screws	Electronics housing		
Stainless steel	Die-cast aluminum	2	
Stainless steel	Stainless steel precision casting <sup>6)</sup>	3	
<b>Version</b>			
• Standard versions		1	
• International version, English label inscriptions, documentation in 5 languages on CD		2	
<b>Explosion protection</b>			
• None			A
• With ATEX, Type of protection:			
- "Intrinsic safety (Ex ia)"			B
- "Explosion-proof (Ex d)" <sup>7)</sup>			D
- "Intrinsic safety and flameproof enclosure" (Ex ia + Ex d)" <sup>8)</sup>			P
- "Ex nA/nL (Zone 2)"			E
- "Intrinsic safety, explosion-proof enclosure and dust explosion protection (Ex ia+ Ex d + Zone 1D/2D)" <sup>8)</sup>			R
• With FM + CSA, Type of protection:			
- "Intrinsic Safe und Explosion Proof (is + xp)" <sup>7)</sup>			NC
<b>Electrical connection / cable entry</b>			
• Screwed gland Pg 13.5 <sup>9)</sup>			A
• Screwed gland M20 x 1.5			B
• Screwed gland 1/2-14 NPT			C
• Han 7D plug (plastic housing) incl. mating connector <sup>9)</sup>			D
• M12 connectors (metal) <sup>10)</sup>			F

Selection and Ordering data		Order No.	
<b>Pressure transmitters for absolute pressure from differential pressure series, SITRANS P DS III HART</b>		F)	7MF4333 -
<b>Display</b>			
• Without indicator			0
• Without visible digital indicator (digital indicator concealed, setting: mA)			1
• With visible digital indicator			6
• with customer-specific digital indicator (setting as specified, Order Code "Y21" or "Y22" required)			7
Power supply units see Chap. 8 "Supplementary Components".			
Included in delivery of the device:			
• Brief instructions (Leporello)			
• CD-ROM with detailed documentation			
• Sealing plug(s) or sealing screw(s) for the process flanges(s)			
1) For oxygen applications, add Order code E10.			
2) Version 7MF4333-1DY... only up to max. span 200 mbar a (2.9 psi a).			
3) When the manufacturer's certificate (calibration certificate) has to be ordered for transmitters with diaphragm seals according to IEC 60770-2, it is recommended only to order this certificate exclusively with the diaphragm seals. The measuring accuracy of the total combination is certified here.			
4) If the acceptance test certificate 3.1 is ordered for the transmitter with mounted diaphragm seals this certificate must also be ordered with the respective remote seals.			
5) Not for span "5.3 ... 100 bar a (76.9 ... 1450 psi a)". Position of the top vent valve in the process flange (see dimensional drawing).			
6) Not in conjunction with Electrical connection "Screwed gland Pg 13.5" and "Han7D plug".			
7) Without cable gland, with blanking plug			
8) With enclosed cable gland Ex ia and blanking plug			
9) Not in conjunction with types of protection "Explosion-proof" and "Ex nA", "Intrinsic safety" and "Explosion-proof".			
10) M12 delivered without cable socket			
E) Combinations of the versions marked with E) are subject to the export regulations AL: 2B230, ECCN: N.			
F) Subject to export regulations AL: 91999, ECCN: N.			

# Pressure Measurement

## Transmitters for general requirements

SITRANS P DS III for absolute pressure  
(from differential pressure series)

Selection and Ordering data		Order No.	
<b>Pressure transmitter for absolute pressure from differential pressure series</b>			
SITRANS P DS III PA (PROFIBUS PA)	F)	7MF4334-	
SITRANS P DS III FF (FOUNDATION Fieldbus)	F)	7MF4335-	
<b>Measuring cell filling</b>		<b>Measuring cell cleaning</b>	
Silicone oil		normal	1
Inert liquid <sup>1)</sup>		Grease-free	3
<b>Nominal measuring range</b>			
250 mbar a	(3.63 psi a)	E)	D
1300 mbar a	(18.9 psi a)	E)	F
5 bar a	(72.5 psi a)	E)	G
30 bar a	(435 psi a)		H
100 bar a	(1450 psi a)		KE
<b>Wetted parts materials</b>			
Seal diaphragm	Parts of measuring cell		
Stainless steel	Stainless steel		
Hastelloy	Stainless steel		
Hastelloy	Hastelloy		
Tantalum	Tantalum		
Monel	Monel	E)	H
Gold	Gold		L
Version as diaphragm seal <sup>2)3)4)</sup>			Y
<b>Process connection</b>			
Female thread 1/4-18 NPT with flange connection			
• Sealing screw opposite process connection			
- Mounting thread 7/16-20 UNF to EN 61518			
- Mounting thread M10 to DIN 19213 (only for replacement requirement)			
• Vent on side of process flange <sup>5)</sup>			
- Mounting thread 7/16-20 UNF to EN 61518			
- Mounting thread M10 to DIN 19213 (only for replacement requirement)			
<b>Non-wetted parts materials</b>			
process flange screws	Electronics housing		
Stainless steel	Die-cast aluminum		
Stainless steel	Stainless steel precision casting		
<b>Version</b>			
• Standard versions			
• International version, English label inscriptions, documentation in 5 languages on CD			
<b>Explosion protection</b>			
• None			
• With ATEX, Type of protection:			
- "Intrinsic safety (Ex ia)"			
- "Explosion-proof (Exd)" <sup>6)</sup>			
- "Intrinsic safety and flameproof enclosure (Ex ia + Ex d)" <sup>7)</sup>			
- "Ex nA/nL (Zone 2)"			
- "Intrinsic safety, explosion-proof enclosure and dust explosion protection (Ex ia + Ex d + Zone 1D/2D)" <sup>7)</sup> (not for DS III FF)			
• With FM + CSA, Type of protection:			
- "Intrinsic Safe und Explosion Proof (is + xp)" <sup>6)</sup>			
<b>Electrical connection / cable entry</b>			
• Screwed gland M20 x 1.5			
• Screwed gland 1/2-14 NPT			
• M12 connectors (metal) <sup>8)</sup>			

Selection and Ordering data		Order No.	
<b>Pressure transmitter for absolute pressure from differential pressure series</b>			
SITRANS P DS III PA (PROFIBUS PA)	F)	7MF4334-	
SITRANS P DS III FF (FOUNDATION Fieldbus)	F)	7MF4335-	
<b>Display</b>			
• Without indicator		0	
• Without visible digital indicator (digital indicator concealed, setting: mA)		1	
• With visible digital indicator		6	
• With customer-specific digital indicator (setting as specified, Order Code "Y21" required)		7	
Included in delivery of the device:			
• Brief instructions (Leporello)			
• CD-ROM with detailed documentation			
• Sealing plug(s) or sealing screw(s) for the process flanges(s)			
1) For oxygen application, add Order code E10.			
2) Version 7MF4334-1DY... only up to max. span 200 mbar a (2.9 psi a).			
3) When the manufacturer's certificate (calibration certificate) has to be ordered for transmitters with diaphragm seals according to IEC 60770-2, it is recommended only to order this certificate exclusively with the diaphragm seals. The measuring accuracy of the total combination is certified here.			
4) If the acceptance test certificate 3.1 is ordered for the transmitter with mounted diaphragm seals this certificate must also be ordered with the respective remote seals.			
5) Not for nominal measuring range 100 bar a (1450 psi a). Position of the top vent valve in the process flange (see dimensional drawing).			
6) Without cable gland, with blanking plug			
7) With enclosed cable gland Ex ia and blanking plug			
8) M12 delivered without cable socket			
E) Combinations of the versions marked with E are subject to the export regulations AL: 2B230, ECCN: N.			
F) Subject to export regulations AL: 91999, ECCN: N.			

# Pressure Measurement

## Transmitters for general requirements

### SITRANS P DS III for absolute pressure (from differential pressure series)

2

Selection and Ordering data	Order code		
	HART	PA	FF
<b>Further designs</b> Add "-Z" to Order No. and specify Order Code.			
<b>Pressure transmitter with mounting bracket (2 shackles, 4 nuts, 4 U-plates, 1 angle) made of:</b>			
• Steel	A01	✓	✓
• Stainless steel	A02	✓	✓
<b>O-rings for process flanges</b> (instead of FPM (Viton))			
• PTFE (Teflon)	A20	✓	✓
• FEP (with silicone core, approved for food)	A21	✓	✓
• FFPM (Kalrez, compound 4079)	A22	✓	✓
• NBR (Buna N)	A23	✓	✓
<b>plug</b>			
• Han 7D (metal, gray)	A30	✓	
• Han 8U (instead of Han 7D)	A31	✓	
• Angled	A32	✓	
• Han 8D (metal, gray)	A33	✓	
<b>Sealing screw</b> ¼-18 NPT, with valve in mat. of process flanges	A40	✓	✓
<b>Cable sockets for M12 connectors (metal)</b>	A50	✓	✓
<b>Rating plate inscription</b> (instead of German)			
• English	B11	✓	✓
• French	B12	✓	✓
• Spanish	B13	✓	✓
• Italian	B14	✓	✓
<b>English rating plate</b> Pressure units in inH <sub>2</sub> O and/or psi	B21	✓	✓
<b>Quality inspection certificate (factory calibration) to IEC 60770-2<sup>1)</sup></b>	C11	✓	✓
<b>Inspection certificate<sup>2)</sup></b> Acc. to EN 10204-3.1	C12	✓	✓
<b>Factory certificate</b> Acc. to EN 10204-2.2	C14	✓	✓
<b>"Functional safety (SIL2)" certificate</b>	C20	✓	
<b>PROFIsafe certificate and protocol</b>	C21		✓
<b>"Functional safety (SIL2/3)" certificate</b>	C23	✓	
<b>Setting of upper limit of output signal to 22.0 mA</b>	D05	✓	
<b>Manufacturer's declaration acc. to NACE</b> (only together with seal diaphragm made of Hastelloy and stainless steel)	D07	✓	✓
<b>Degree of protection IP68</b> (only for M20 x 1.5 and ½-14 NPT)	D12	✓	✓
<b>Supplied with oval flange</b> (1 item), PTFE packing and screws in thread of process flange	D37	✓	✓
<b>Use in or on zone 1D/2D</b> (only together with type of protection "Intrinsic safety (EEx ia)")	E01	✓	✓
<b>Oxygen application</b> (In the case of oxygen measurement and inert liquid max. 120 bar a (1740 psi a) at 60°C (140 °F))	E10	✓	✓
<b>Explosion-proof "Intrinsic safety" to INMETRO (Brazil)</b> (only for transmitter 7MF4...-.....-B..)	E25	✓	✓
<b>Ex Approval IEC Ex (EEx ia)</b> (only for transmitter 7MF4...-.....-B..)	E45	✓	✓

Selection and Ordering data	Order code		
	HART	PA	FF
<b>Further designs</b> Add "-Z" to Order No. and specify Order Code.			
<b>Ex Approval IEC Ex (EEx id)</b> (only for transmitter 7MF4...-.....-D..)	E46	✓	✓
<b>Explosion-proof "Intrinsic safety" to NEPSI (China)</b> (only for transmitter 7MF4...-.....-B..)	E55	✓	✓
<b>Explosion protection "Explosion-proof" to NEPSI (China)</b> (only for transmitter 7MF4...-.....-D..)	E56	✓	✓
<b>Explosion-proof "Zone 2" to NEPSI (China)</b> (only for transmitter 7MF4...-.....-E..)	E57	✓	✓
<b>Two coats of lacquer on casing and cover (PU on epoxy)</b>	G10	✓	✓
<b>Interchanging of process connection side</b>	H01	✓	✓
<b>Vent on side for gas measurements</b>	H02	✓	✓
<b>Process flange</b>			
• Hastelloy	K01 <sup>F)</sup>	✓	✓
• Monel	K02 <sup>F)</sup>	✓	✓
• Stainless steel with PVDF insert max. PN 10 (MWP 145 psi), max. temperature of medium 90 °C (194 °F) For ½-14 NPT inner process connection on the side in the middle of the process flange, vent valve not possible	K04 <sup>F)</sup>	✓	✓

# Pressure Measurement

## Transmitters for general requirements

SITRANS P DS III for absolute pressure  
(from differential pressure series)

2

Selection and Ordering data	Order code		
	HART	PA	FF
<b>Additional data</b>			
Please add <b>"-Z"</b> to Order No. and specify Order code(s) and plain text.			
<b>Measuring range to be set</b> Specify in plain text (max. 5 characters): Y01: ... up to ... mbar, bar, kPa, MPa, psi	Y01	✓	
<b>Stainless steel tag plate (measuring point description)</b> Max. 16 characters, specify in plain text: Y15: .....	Y15	✓	✓
<b>Measuring point text</b> Max. 27 characters, specify in plain text: Y16: .....	Y16	✓	✓
<b>Entry of HART address (TAG)</b> Max. 8 characters, specify in plain text: Y17: .....	Y17	✓	
<b>Setting of pressure indication in pressure units</b> Specify in plain text (standard setting: bar): Y21: mbar, bar, kPa, MPa, psi, ... Note: The following pressure units can be selected: bar, mbar, mm H <sub>2</sub> O <sup>1)</sup> , inH <sub>2</sub> O <sup>1)</sup> , ftH <sub>2</sub> O <sup>1)</sup> , mmHG, inHG, psi, Pa, kPa, MPa, g/cm <sup>2</sup> , kg/cm <sup>2</sup> , Torr, ATM or % ) ref. temperature 20 °C	Y21	✓	✓
<b>Setting of pressure indication in non-pressure units<sup>3)</sup></b> Specify in plain text: Y22: ..... up to ..... l/min, m <sup>3</sup> /h, m, USgpm, ... (specification of measuring range in pressure units "Y01" is essential, unit with max. 5 characters)	Y22 + Y01	✓	
<b>Preset bus address</b> possible between 1 and 126 Specify in plain text: Y25: .....	Y25		✓

Factory mounting of valve manifolds, see accessories.

Only "Y01", "Y21", "Y22", "Y25" and "D05" can be factory preset

✓ = available

- 1) When the manufacture's certificate (calibration certificate) has to be ordered for transmitters with diaphragm seals according to IEC 60770-2, it is recommended only to order this certificate exclusively with the diaphragm seals. The measuring accuracy of the total combination is certified here.
- 2) If the acceptance test certificate 3.1 is ordered for the transmitter with mounted diaphragm seals this certificate must also be ordered with the respective remote seals.
- 3) Preset values can only be changed over SIMATIC PDM.

# Pressure Measurement

## Transmitters for general requirements

SITRANS P DS III for absolute pressure  
(from differential pressure series)

### Dimensional drawings

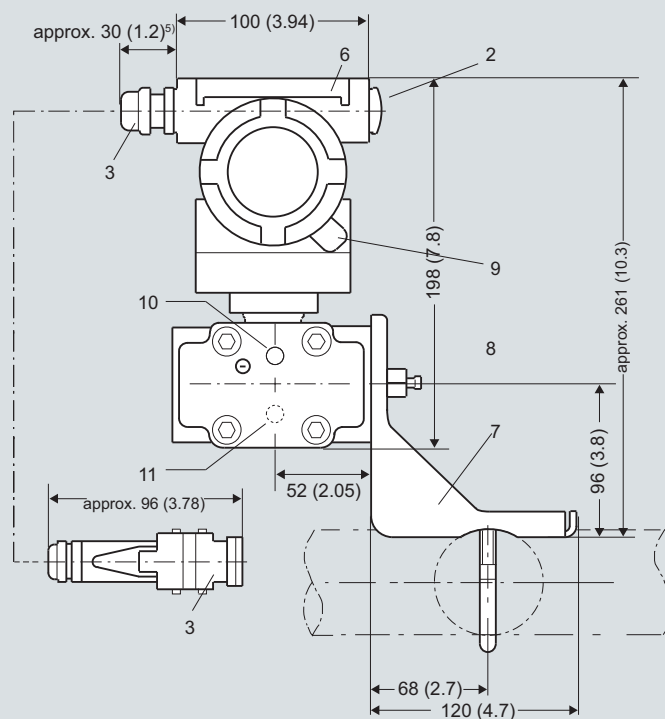
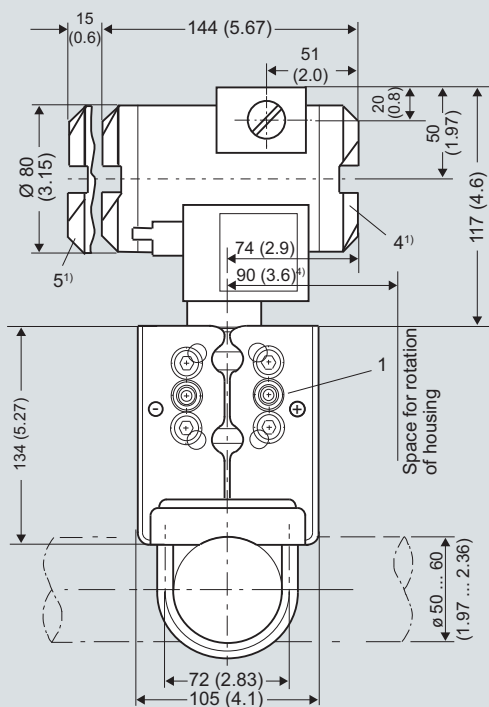

- 1 Process connection: 1/4-18 NPT (EN 61518)
- 2 Blanking plug
- 3 Electrical connection:
  - Screwed gland Pg 13,5 (adapter)<sup>2)3)</sup>, only DS III HART,
  - Screwed gland M20x1,5<sup>3)</sup>,
  - Screwed gland 1/2-14 NPT,
  - Han 7D/Han 8D<sup>2)3)</sup> plug, only DS III HART, or
  - M12 connector
- 4 Terminal side
- 5 Electronics side, digital display (longer overall length for cover with window)
- 6 Protective cover over keys
- 7 Mounting bracket (option)
- 8 Sealing screw with valve (option)
- 9 Screw cover - safety bracket (only for type of protection "Explosion-proof enclosure", not shown in the drawing)
- 10 Lateral venting for liquid measurement (Standard)
- 11 Lateral venting for gas measurement (suffix H02)

- 1) Allow approx. 20 mm (0.79 inch) thread length to permit unscrewing
- 2) Not with type of protection "explosion-proof enclosure"
- 3) Not with type of protection "FM + CSA [is + xp]"
- 4) 92 mm (3.62 inch) for minimum distance to permit rotation with indicator
- 5) 45 mm (1.8 inch) for Pg 13,5 with adapter

SITRANS P DS III pressure transmitters for absolute pressure, from the differential pressure series, dimensions in mm (inch)

# Pressure Measurement

## Transmitters for general requirements

SITRANS P DS III  
for differential pressure and flow

### Technical specifications

SITRANS P, DS III for differential pressure and flow				
	HART		PROFIBUS PA and FOUNDATION Fieldbus	
<b>Input</b>	Differential pressure and flow			
Measured variable	Span			
Spans (infinitely adjustable) or nominal measuring range and max. permissible operating pressure	Span	Maximum operating pressure	Nominal measuring range	Maximum operating pressure
	1 ... 20 mbar (0.4 ... 8 inH <sub>2</sub> O)	32 bar (464 psi)	20 mbar (8 inH <sub>2</sub> O)	32 bar (464 psi)
	1 ... 60 mbar (0.4 ... 24 inH <sub>2</sub> O)	160 bar (2320 psi)	60 mbar (24 inH <sub>2</sub> O)	160 bar (2320 psi)
	2.5 ... 250 mbar (1 ... 100 inH <sub>2</sub> O)		250 mbar (100 inH <sub>2</sub> O)	
	6 ... 600 mbar (2.4 ... 240 inH <sub>2</sub> O)		600 mbar (240 inH <sub>2</sub> O)	
	16 ... 1600 mbar (6.4 ... 642 inH <sub>2</sub> O)		1600 mbar (642 inH <sub>2</sub> O)	
	50 ... 5000 mbar (20 ... 2000 inH <sub>2</sub> O)		5 bar (2000 inH <sub>2</sub> O)	
	0.3 ... 30 bar (4.35 ... 435 psi)		30 bar (435 psi)	
	2.5 ... 250 mbar (1 ... 100 inH <sub>2</sub> O)	420 bar (6091 psi)	250 mbar (100 inH <sub>2</sub> O)	420 bar (6091 psi)
	6 ... 600 mbar (2.4 ... 240 inH <sub>2</sub> O)		600 mbar (240 inH <sub>2</sub> O)	
	16 ... 1600 mbar (6.4 ... 642 inH <sub>2</sub> O)		1600 mbar (642 inH <sub>2</sub> O)	
	50 ... 5000 mbar (20 ... 2000 inH <sub>2</sub> O)		5 bar (2000 inH <sub>2</sub> O)	
	0.3 ... 30 bar (4.35 ... 435 psi)		30 bar (435 psi)	
Lower measuring limit	-100 % of max. span (-33 % with 30 bar (435 psi) measuring cell or 30 mbar a (0.44 psi))			
• Measuring cell with silicone oil filling				
Upper measuring limit	100 % of max. span (for oxygen version and inert filling liquid; max. 160 bar g (2320 psi g))			
<b>Output</b>	4 ... 20 mA			
Output signal	4 ... 20 mA		Digital PROFIBUS PA and FOUNDATION Fieldbus signal	
• Lower limit (infinitely adjustable)	3.55 mA, factory preset to 3.84 mA		-	
• Upper limit (infinitely adjustable)	23 mA, factory preset to 20.5 mA or optionally set to 22.0 mA		-	
Load	-			
• Without HART communication	$R_B \leq (U_H - 10.5 \text{ V})/0.023 \text{ A}$ in $\Omega$ , $U_H$ : Power supply in V		-	
• With HART communication	$R_B = 230 \dots 500 \Omega$ (SIMATIC PDM) or $R_B = 230 \dots 1100 \Omega$ (HART Communicator)		-	
Physical bus	-		IEC 61158-2	
Protection against polarity reversal	Protected against short-circuit and polarity reversal. Each connection against the other with max. supply voltage.			
<b>Measuring accuracy</b>	Acc. to EN 60770-1			
Reference conditions (All error data refer always refer to the set span)	Increasing characteristic, start-of-scale value 0 bar, stainless steel seal diaphragm, silicone oil filling, room temperature 25 °C (77 °F) r: Span ratio (r = max. span / set span)			
Error in measurement and fixed-point setting (including hysteresis and repeatability)			≤ 0.075 %	
• Linear characteristic				
- r ≤ 10	≤ (0.0029 · r + 0.071) %			
- 10 < r ≤ 30	≤ (0.0045 · r + 0.071) %			
- 30 < r ≤ 100	≤ (0.005 · r + 0.05) %			
• Square-rooted characteristic (flow > 50 %)			≤ 0,1 %	
- r ≤ 10	≤ 0.1 %			
- 10 < r ≤ 30	≤ 0.2 %			

# Pressure Measurement

## Transmitters for general requirements

### SITRANS P DS III for differential pressure and flow

2

SITRANS P, DS III for differential pressure and flow		
	HART	PROFIBUS PA and FOUNDATION Fieldbus
<ul style="list-style-type: none"> <li>• Square-rooted characteristic (flow &gt; 25 ... 50 %)               <ul style="list-style-type: none"> <li>- <math>r \leq 10</math></li> <li>- <math>10 &lt; r \leq 30</math></li> </ul> </li> </ul>	<ul style="list-style-type: none"> <li><math>\leq 0.2 \%</math></li> <li><math>\leq 0.4 \%</math></li> </ul>	$\leq 0.2$
Long-term drift (temperature change $\pm 30 \text{ }^\circ\text{C}$ ( $\pm 5 \text{ }^\circ\text{F}$ ))	$\leq (0.25 \cdot r)\%$ every 5 years static pressure max. 70 bar g (1015 psi g)	$\leq 0.25 \%$ every 5 years static pressure max. 70 bar g (1015 psi g)
<ul style="list-style-type: none"> <li>• 20 mbar (0.29 psi)-measuring cell</li> <li>• 250, 600, 1600 and 5000 mbar (0.29, 0.87, 2.32 and 7.25 psi) -measuring cell</li> </ul>	<ul style="list-style-type: none"> <li><math>\leq (0.2 \cdot r)</math> per year</li> <li><math>\leq (0.125 \cdot r)</math> per year</li> </ul>	<ul style="list-style-type: none"> <li><math>\leq 0.2</math> per year</li> <li><math>\leq 0.125</math> per year</li> </ul>
Influence of ambient temperature		
<ul style="list-style-type: none"> <li>• at <math>-10 \dots +60 \text{ }^\circ\text{C}</math> (<math>14 \dots 140 \text{ }^\circ\text{F}</math>)</li> <li>• at <math>-40 \dots -10 \text{ }^\circ\text{C}</math> and <math>60 \dots 85 \text{ }^\circ\text{C}</math> (<math>-40 \dots +14 \text{ }^\circ\text{F}</math> and <math>140 \dots 185 \text{ }^\circ\text{F}</math>)</li> </ul>	<ul style="list-style-type: none"> <li><math>\leq (0.08 \cdot r + 0.1) \%</math></li> <li><math>\leq (0.1 \cdot r + 0.15)\%/10 \text{ K}</math> (Twice the value with 20-mbar (0.29 psi) measuring cell)</li> </ul>	<ul style="list-style-type: none"> <li><math>\leq 0.3 \%</math></li> <li><math>\leq 0.25 \%/10 \text{ K}</math></li> </ul>
Influence of static pressure		
<ul style="list-style-type: none"> <li>• on the zero point (PKN)               <ul style="list-style-type: none"> <li>- 20 mbar (0.29 psi)-measuring cell</li> </ul> </li> <li>• on the span (PKS)               <ul style="list-style-type: none"> <li>- 20 mbar (0.29 psi)-measuring cell</li> </ul> </li> </ul>	<ul style="list-style-type: none"> <li><math>\leq (0.15 \cdot r)\%</math> per 70 bar (1015 psi)</li> <li><math>\leq (0.15 \cdot r)\%</math> per 32 bar (464 psi)</li> <li><math>\leq 0.2 \%</math> per 70 bar (1015 psi)</li> <li><math>\leq 0.2 \%</math> per 32 bar (464 psi)</li> </ul>	<ul style="list-style-type: none"> <li><math>\leq 0.15 \%</math> per 70 bar (1015 psi)</li> <li><math>\leq 0.15 \%</math> per 32 bar (464 psi)</li> <li>-</li> <li>-</li> </ul>
Measured Value Resolution	-	$3 \cdot 10^{-5}$ of nominal measuring range
<b>Rated conditions</b>		
Degree of protection (to EN 60529)		IP65
Temperature of medium		
<ul style="list-style-type: none"> <li>• Measuring cell with silicone oil filling</li> <li>• Measuring cell with inert filling liquid</li> <li>• In conjunction with dust explosion protection</li> </ul>		<ul style="list-style-type: none"> <li><math>-40 \dots +100 \text{ }^\circ\text{C}</math> (<math>-40 \dots +212 \text{ }^\circ\text{F}</math>)</li> <li><math>-20 \dots +100 \text{ }^\circ\text{C}</math> (<math>-4 \dots +212 \text{ }^\circ\text{F}</math>)</li> <li><math>-20 \dots +60 \text{ }^\circ\text{C}</math> (<math>-4 \dots +140 \text{ }^\circ\text{F}</math>)</li> </ul>
Ambient conditions		
<ul style="list-style-type: none"> <li>• Ambient temperature               <ul style="list-style-type: none"> <li>- Digital indicator</li> </ul> </li> <li>• Storage temperature</li> <li>• Climatic class               <ul style="list-style-type: none"> <li>- Condensation</li> </ul> </li> </ul>		<ul style="list-style-type: none"> <li><math>-30 \dots +85 \text{ }^\circ\text{C}</math> (<math>-22 \dots +185 \text{ }^\circ\text{F}</math>)</li> <li><math>-50 \dots +85 \text{ }^\circ\text{C}</math> (<math>-58 \dots +185 \text{ }^\circ\text{F}</math>)</li> <li>Relative humidity 0 ... 100 %</li> <li>Condensation permissible, suitable for use in the tropics</li> </ul>
<ul style="list-style-type: none"> <li>• Electromagnetic Compatibility               <ul style="list-style-type: none"> <li>- Emitted interference and interference immunity</li> </ul> </li> </ul>		Acc. to EN 61326 and NAMUR NE 21
<b>Design</b>		
Weight (without options)		$\approx 4.5 \text{ kg}$ ( $\approx 9.9 \text{ lb}$ )
Enclosure material		Low-copper die-cast aluminum, GD-AlSi12 or stainless steel precision casting, mat. no. 1.4408
Wetted parts materials		
<ul style="list-style-type: none"> <li>• Seal diaphragm</li> </ul>		Stainless steel, mat. no. 1.4404/316L or Hastelloy C276, mat. no. 2.4819, Monel, mat. no. 2.4360, tantalum or gold
Measuring cell filling		Silicone oil or inert filling liquid (maximum value with oxygen measurement pressure 120 bar a) (1740 psi a) at $60 \text{ }^\circ\text{C}$ ( $140 \text{ }^\circ\text{F}$ ))
Process connection		Female thread $\frac{1}{4}$ -18 NPT and flange connection with mounting thread M10 to DIN 19213 or $\frac{7}{16}$ -20 UNF to EN 61518
Material of mounting bracket		
<ul style="list-style-type: none"> <li>• Steel</li> <li>• Stainless steel</li> </ul>		Sheet-steel, Mat. No. 1.0330, chrome-plated Sheet stainless steel, mat. no. 1.4301 (SS 304)
<b>Power supply <math>U_H</math></b>		Supplied through bus
Terminal voltage on transmitter	10.5 ... 45 V DC 10.5 ... 30 V DC in intrinsically-safe mode	-
Separate 24 V power supply necessary	-	No
Bus voltage		
<ul style="list-style-type: none"> <li>• Not Ex</li> <li>• With intrinsically-safe operation</li> </ul>	-	9 ... 32 V 9 ... 24 V

# Pressure Measurement

## Transmitters for general requirements

SITRANS P DS III  
for differential pressure and flow

2

SITRANS P, DS III for differential pressure and flow	HART	PROFIBUS PA and FOUNDATION Fieldbus
Current consumption		
• Basic current (max.)	-	12.5 mA
• Start-up current $\leq$ basic current	-	Yes
• Max. current in event of fault	-	15.5 mA
Fault disconnection electronics (FDE) available	-	Yes
<b>Certificates and approvals</b>		
Classification according to PED 97/23/EC PN 32/160 (MWP 464/2320 psi)	For gases of fluid group 1 and liquids of fluid group 1; complies with requirements of article 3, paragraph 3 (sound engineering practice)	
PN 420 (MWP 6092 psi)	For gases of fluid group 1 and liquids of fluid group 1; complies with basic safety requirements of Article 3, paragraph 1 (appendix 1); assigned to category III, conformity evaluation module H by the TÜV Nord.	
Explosion protection		
• Intrinsic safety "i"	PTB 99 ATEX 2122	
- Marking	Ex II 1/2 G EEx ia/ib IIB/IIC T6	
- Permissible ambient temperature	-40 ... +85 °C (-40 ... +185 °F) temperature class T4; -40 ... +70 °C (-40 ... +158 °F) temperature class T5; -40 ... +60 °C (-40 ... +140 °F) temperature class T6	
- Connection	To certified intrinsically-safe circuits with peak values: $U_i = 30 \text{ V}$ , $I_i = 100 \text{ mA}$ , $P_i = 750 \text{ mW}$ ; $R_i = 300 \Omega$	FISCO supply unit: $U_o = 17.5 \text{ V}$ , $I_o = 380 \text{ mA}$ , $P_o = 5.32 \text{ W}$ Linear barrier: $U_o = 24 \text{ V}$ , $I_o = 250 \text{ mA}$ , $P_o = 1.2 \text{ W}$
- Effective internal inductance/capacitance	$L_i = 0.4 \text{ mH}$ , $C_i = 6 \text{ nF}$	$L_i = 7 \mu\text{H}$ , $C_i = 1.1 \text{ nF}$
• Explosion-proof "d"	PTB 99 ATEX 1160	
- Marking	Ex II 1/2 G EEx d IIC T4/T6	
- Permissible ambient temperature	-40 ... +85 °C (-40 ... +185 °F) temperature class T4; -40 ... +60 °C (-40 ... +140 °F) temperature class T6	
- Connection	To circuits with values: $U_H = 10.5 \dots 45 \text{ V DC}$	To circuits with values: $U_H = 9 \dots 32 \text{ V DC}$
• Dust explosion protection for zone 20	PTB 01 ATEX 2055	
- Marking	Ex II 1 D IP65 T 120 °C Ex II 1/2 D IP65 T 120 °C	
- Permissible ambient temperature	-40 ... +85 °C (-40 ... +185 °F)	
- Max. surface temperature	120 °C (248 °F)	
- Connection	To certified intrinsically-safe circuits with peak values: $U_i = 30 \text{ V}$ , $I_i = 100 \text{ mA}$ , $P_i = 750 \text{ mW}$ , $R_i = 300 \Omega$	FISCO supply unit: $U_o = 17.5 \text{ V}$ , $I_o = 380 \text{ mA}$ , $P_o = 5.32 \text{ W}$ Linear barrier: $U_o = 24 \text{ V}$ , $I_o = 250 \text{ mA}$ , $P_o = 1.2 \text{ W}$
- Effective internal inductance/capacitance	$L_i = 0.4 \text{ mH}$ , $C_i = 6 \text{ nF}$	$L_i = 7 \mu\text{H}$ , $C_i = 1.1 \text{ nF}$
• Dust explosion protection for zone 21/22	PTB 01 ATEX 2055	
- Marking	Ex II 2 D IP65 T 120 °C	
- Connection	To circuits with values: $U_H = 10.5 \dots 45 \text{ V DC}$ ; $P_{\text{max}} = 1.2 \text{ W}$	To circuits with values: $U_H = 9 \dots 32 \text{ V DC}$ ; $P_{\text{max}} = 1.2 \text{ W}$
• Type of protection "n" (zone 2)	TÜV 01 ATEX 1696 X	
- Marking	Ex II 3 G EEx nA L IIC T4/T5/T6	-
• Explosion protection acc. to FM	Certificate of Compliance 3008490	
- Identification (XP/DIP) or (IS); (NI)	CL I, DIV 1, GP ABCD T4...T6; CL II, DIV 1, GP EFG; CL III; CL I, ZN 0/1 AEx ia IIC T4...T6; CL I, DIV 2, GP ABCD T4...T6; CL II, DIV 2, GP FG; CL III	
• Explosion protection to CSA	Certificate of Compliance 1153651	
- Identification (XP/DIP) or (IS)	CL I, DIV 1, GP ABCD T4...T6; CL II, DIV 1, GP EFG; CL III; Ex ia IIC T4...T6; CL I, DIV 2, GP ABCD T4...T6; CL II, DIV 2, GP FG; CL III	

# Pressure Measurement

## Transmitters for general requirements

### SITRANS P DS III for differential pressure and flow

2

#### HART communication

HART communication	230 ... 1100 Ω
Protocol	HART Version 5.x

#### PROFIBUS PA communication

Simultaneous communication with master class 2 (max.)	4
The address can be set using	Configuration tool or local operation (standard setting address 126)
Cyclic data usage	
• Output byte	5 (one measured value) or 10 (two measured values)
• Input byte	0, 1, or 2 (register operating mode and reset function for metering)
Internal preprocessing	
Device profile	PROFIBUS PA Profile for Process Control Devices Version 3.0, Class B
Function blocks	2
• Analog input	
- Adaptation to customer-specific process variables	Yes, linearly rising or falling characteristic
- Electrical damping $T_{63}$ , adjustable	0 ... 100 s
- Simulation function	Input /Output
- Failure mode	parameterizable (last good value, substitute value, incorrect value)
- Limit monitoring	Yes, one upper and lower warning limit and one alarm limit respectively
• Register (totalizer)	Can be reset, preset, optional direction of counting, simulation function of register output
- Failure mode	parameterizable (summation with last good value, continuous summation, summation with incorrect value)
- Limit monitoring	One upper and lower warning limit and one alarm limit respectively
• Physical block	1
Transducer blocks	2
• Pressure transducer block	
- Can be calibrated by applying two pressures	Yes
- Monitoring of sensor limits	Yes
- Specification of a container characteristic with	Max. 30 nodes
- Square-rooted characteristic for flow measurement	Yes
- Gradual volume suppression and implementation point of square-root extraction	Parameterizable
- Simulation function for measured pressure value and sensor temperature	Constant value or over parameterizable ramp function

#### FOUNDATION Fieldbus communication

Function blocks	3 function blocks analog input, 1 function block PID
• Analog input	
- Adaptation to customer-specific process variables	Yes, linearly rising or falling characteristic
- Electrical damping $T_{63}$ , adjustable	0 ... 100 s
- Simulation function	Output/input (can be locked within the device with a bridge)
- Failure mode	parameterizable (last good value, substitute value, incorrect value)
- Limit monitoring	Yes, one upper and lower warning limit and one alarm limit respectively
- Square-rooted characteristic for flow measurement	Yes
• PID	Standard FF function block
• Physical block	1 resource block
Transducer blocks	1 transducer block Pressure with calibration, 1 transducer block LCD
• Pressure transducer block	
- Can be calibrated by applying two pressures	Yes
- Monitoring of sensor limits	Yes
- Simulation function: Measured pressure value, sensor temperature and electronics temperature	Constant value or over parameterizable ramp function

# Pressure Measurement

## Transmitters for general requirements

**SITRANS P DS III**  
 for differential pressure and flow

Selection and Ordering data		Order No.
<b>SITRANS P DS III HART pressure transmitters for differential pressure and flow, PN 32/160 (MWP 464/2320 psi)</b>		<b>7MF4433-</b>
<b>Measuring cell filling</b>	<b>Measuring cell cleaning</b>	
Silicone oil	normal	▶ 1
Inert liquid <sup>1)</sup>	Grease-free	▶ 3
<b>Measuring span</b>		
PN 32 (MWP 464 psi)		
1 ... 20 mbar <sup>2)</sup>	(0.4015 ... 8.03 inH <sub>2</sub> O)	▶ B
PN 160 (MWP 2320 psi)		
1 ... 60 mbar	(0.4015 ... 24.09 inH <sub>2</sub> O)	▶ C
2,5 ... 250 mbar	(1.004 ... 100.4 inH <sub>2</sub> O)	▶ D
6 ... 600 mbar	(2.409 ... 240.9 inH <sub>2</sub> O)	▶ E
16 ... 1600 mbar	(6.424 ... 642.4 inH <sub>2</sub> O)	▶ F
50 ... 5000 mbar	(20.08 ... 2008 inH <sub>2</sub> O)	▶ G
0,3 ... 30 bar	(4.35 ... 435 psi)	▶ H
<b>Wetted parts materials</b>		
(stainless steel process flanges)		
Seal diaphragm	Parts of measuring cell	
Stainless steel	Stainless steel	▶ A
Hastelloy	Stainless steel	B
Hastelloy	Hastelloy	C
Tantalum <sup>3)</sup>	Tantalum	E
Monel <sup>3)</sup>	Monel	H
Gold <sup>3)</sup>	Gold	L
Version for diaphragm seal <sup>4)5)</sup>		Y
<b>Process connection</b>		
Female thread 1/4-18 NPT with flange connection		
• Sealing screw opposite process connection		
- Mounting thread 7/16-20 UNF to EN 61518		▶ 2
- Mounting thread M10 to DIN 19213 (only for replacement requirement)		0
• Vent on side of process flange <sup>2)</sup>		
- Mounting thread 7/16-20 UNF to EN 61518		6
- Mounting thread M10 to DIN 19213 (only for replacement requirement)		4
<b>Non-wetted parts materials</b>		
process flange screws	Electronics housing	
Stainless steel	Die-cast aluminum	▶ 2
Stainless steel	Stainless steel precision casting <sup>6)</sup>	3
<b>Version</b>		
• Standard versions		1
• International version, English label inscriptions, documentation in 5 languages on CD		▶ 2
<b>Explosion protection</b>		
• None		A
• With ATEX, Type of protection:		
- "Intrinsic safety (EEx ia)"		B
- "Explosion-proof (EEx d)" <sup>7)</sup>		D
- "Intrinsic safety and flameproof enclosure" (EEx ia + EEx d) <sup>8)</sup>		P
- "Ex nA/nL (Zone 2)"		E
- "Intrinsic safety, explosion-proof enclosure and dust explosion protection (EEx ia+ EEx d + Zone 1D/2D)" <sup>8)</sup>		▶ R
• With FM + CSA, Type of protection:		
- "Intrinsic Safe und Explosion Proof (is + xp)" <sup>7)</sup>		NC

Selection and Ordering data		Order No.
<b>SITRANS P DS III HART pressure transmitters for differential pressure and flow, PN 32/160 (MWP 464/2320 psi)</b>		<b>7MF4433-</b>
<b>Electrical connection / cable entry</b>		
• Screwed gland Pg 13.5 <sup>9)</sup>		▶ A
• Screwed gland M20 x 1.5		B
• Screwed gland 1/2-14 NPT		C
• Han 7D plug (plastic housing) incl. mating connector <sup>9)10)</sup>		D
• M12 connectors (metal) <sup>11)</sup>		F
<b>Display</b>		
• Without indicator		0
• Without visible digital indicator (digital indicator concealed, setting: mA)		▶ 1
• With visible digital indication		6
• with customer-specific digital indicator (setting as specified, Order Code "Y21" or "Y22" required)		7

▶ Available ex stock

Power supply units see Chap. 8 "Supplementary Components".

Included in delivery of the device:

- Brief instructions (Leporello)
- CD-ROM with detailed documentation
- Sealing plug(s) or sealing screw(s) for the process flanges(s)

- 1) For oxygen application, add Order code E10.
- 2) Not suitable for connection of remote seal. Position of the top vent valve in the process flange (see dimensional drawing).
- 3) Not in conjunction with max. span 20 and 60 mbar (8.03 und 24.09 inH<sub>2</sub>O))
- 4) When the manufacture's certificate (calibration certificate) has to be ordered for transmitters with diaphragm seals according to IEC 60770-2, it is recommended only to order this certificate exclusively with the diaphragm seals. The measuring accuracy of the total combination is certified here.
- 5) If the acceptance test certificate 3.1 is ordered for the transmitter with mounted diaphragm seals this certificate must also be ordered with the respective remote seals.
- 6) Not in conjunction with Electrical connection "Screwed gland Pg 13.5" and "Han7D plug".
- 7) Without cable gland, with blanking plug
- 8) With enclosed cable gland EEx ia and blanking plug
- 9) Not in conjunction with types of protection "Explosion-proof" and "Ex nA", "Intrinsic safety" and "Explosion-proof".
- 10) Permissible only for crimp-contact of conductor cross-section 1 mm<sup>2</sup>
- 11) M12 delivered without cable socket

# Pressure Measurement

## Transmitters for general requirements

### SITRANS P DS III for differential pressure and flow

2

Selection and Ordering data		Order No.
<b>Pressure transmitters for differential pressure and flow PN 32/160 (MWP 464/2320 psi)</b>		
<b>SITRANS P DS III PA (PROFIBUS PA)</b>		7 MF 4 4 3 4 -
<b>SITRANS P DS III FF (FOUNDATION Fieldbus)</b>		7 MF 4 4 3 5 -
<b>Measuring cell filling</b>		
Silicone oil	normal	1
Inert liquid <sup>1)</sup>	Grease-free	3
<b>Nominal measuring range</b>		
PN 32 (MWP 464 psi)		
20 mbar <sup>2)</sup>	(8.03 inH <sub>2</sub> O)	B
PN 160 (MWP 2320 psi)		
60 mbar	(24.09 inH <sub>2</sub> O)	C
250 mbar	(100.4 inH <sub>2</sub> O)	D
600 mbar	(240.9 inH <sub>2</sub> O)	E
1600 mbar	(642.4 inH <sub>2</sub> O)	F
5 bar	(2008 inH <sub>2</sub> O)	G
30 bar	(435 psi)	H
<b>Wetted parts materials</b>		
(stainless steel process flanges)		
Seal diaphragm	Parts of measuring cell	
Stainless steel	Stainless steel	A
Hastelloy	Stainless steel	B
Hastelloy	Hastelloy	C
Tantalum <sup>3)</sup>	Tantalum	E
Monel <sup>3)</sup>	Monel	H
Gold <sup>3)</sup>	Gold	L
Version as diaphragm seal <sup>4)5)</sup>		Y
<b>Process connection</b>		
Female thread 1/4-18 NPT with flange connection		
• Sealing screw opposite process connection		
- Mounting thread 7/16-20 UNF to EN 61518		2
- Mounting thread M10 to DIN 19213 (only for replacement requirement)		0
• Venting on side of process flanges <sup>2)</sup>		
- Mounting thread 7/16-20 UNF to EN 61518		6
- Mounting thread M10 to DIN 19213 (only for replacement requirement)		4
<b>Non-wetted parts materials</b>		
process flange screws	Electronics housing	
Stainless steel	Die-cast aluminum	2
Stainless steel	Stainless steel precision casting	3
<b>Version</b>		
• Standard versions		1
• International version, English label inscriptions, documentation in 5 languages on CD		2
<b>Explosion protection</b>		
• None		A
• With ATEX, Type of protection:		
- "Intrinsic safety (EEx ia)"		B
- "Explosion-proof (EEx d)" <sup>6)</sup>		D
- "Intrinsic safety and flameproof enclosure" (EEx ia + EEx d)" <sup>7)</sup>		P
- "Ex nA/nL (Zone 2)"		E
- "Intrinsic safety, explosion-proof enclosure and dust explosion protection (EEx ia + EEx d + Zone 1D/2D)" <sup>7)</sup> (not for DS III FF)		R
• With FM + CSA, Type of protection:		
- "Intrinsic Safe und Explosion Proof (is + xp)" <sup>6)</sup>		NC

Selection and Ordering data		Order No.
<b>Pressure transmitters for differential pressure and flow PN 32/160 (MWP 464/2320 psi)</b>		
<b>SITRANS P DS III PA (PROFIBUS PA)</b>		7 MF 4 4 3 4 -
<b>SITRANS P DS III FF (FOUNDATION Fieldbus)</b>		7 MF 4 4 3 5 -
<b>Electrical connection / cable entry</b>		
• Screwed gland M20 x 1.5		B
• Screwed gland 1/2-14 NPT		C
• M12 connectors (metal) <sup>8)</sup>		F
<b>Display</b>		
• Without indicator		0
• Without visible digital indicator(digital indicator concealed, setting: mA)		1
• With visible digital indication		6
• With customer-specific digital indication (setting as specified, Order Code "Y21" required)		7
▶ Available ex stock		
Included in delivery of the device:		
• Brief instructions (Leporello)		
• CD-ROM with detailed documentation		
• Sealing plug(s) or sealing screw(s) for the process flanges(s)		
1) For oxygen application, add Order code E10.		
2) Not suitable for connection of remote seal. Position of the top vent valve in the process flange (see dimensional drawing).		
3) Not in conjunction with max. span 20 and 60 mbar (8.03 und 24.09 inH <sub>2</sub> O))		
4) When the manufacture's certificate (calibration certificate) has to be ordered for transmitters with diaphragm seals according to IEC 60770-2, it is recommended only to order this certificate exclusively with the diaphragm seals. The measuring accuracy of the total combination is certified here.		
5) If the acceptance test certificate 3.1.is ordered for the transmitter with mounted diaphragm seals this certificate must also be ordered with the respective remote seals.		
6) Without cable gland, with blanking plug.		
7) With enclosed cable gland EEx ia and blanking plug.		
8) M12 delivered without cable socket		

# Pressure Measurement

## Transmitters for general requirements

**SITRANS P DS III**  
 for differential pressure and flow

Selection and Ordering data	Order code		
<i>Further designs</i>	HART	PA	FF
Add "-Z" to Order No. and specify Order Code.			
<b>Pressure transmitter with mounting bracket (2 shackles, 4 nuts, 4 U-plates, 1 angle) made of:</b>			
• Steel	A01	✓	✓
• Stainless steel	A02	✓	✓
<b>O-rings for process flanges</b> (instead of FPM (Viton))			
• PTFE (Teflon)	A20	✓	✓
• FEP (with silicone core, approved for food)	A21	✓	✓
• FFFM (Kalrez, compound 4079)	A22	✓	✓
• NBR (Buna N)	A23	✓	✓
<b>plug</b>			
• Han 7D (metal, gray)	A30	✓	✓
• Han 8U (instead of Han 7D)	A31	✓	✓
• Angled	A32	✓	✓
• Han 8D (metal, gray)	A33	✓	✓
<b>Sealing screws (2 unit(s))</b>	A40	✓	✓
¼-18 NPT, with valve in mat. of process flanges			
<b>Cable sockets for M12 connectors (metal)</b>	A50	✓	✓
<b>Rating plate inscription</b> (instead of German)			
• English	B11	✓	✓
• French	B12	✓	✓
• Spanish	B13	✓	✓
• Italian	B14	✓	✓
<b>English rating plate</b>	B21	✓	✓
Pressure units in inH <sub>2</sub> O and/or psi			
<b>Quality inspection certificate (factory calibration) to IEC 60770-2<sup>1)</sup></b>	C11	✓	✓
<b>Inspection certificate<sup>2)</sup> to EN 10204-3.1</b>	C12	✓	✓
<b>Factory certificate to EN 10204-2.2</b>	C14	✓	✓
<b>"Functional safety (SIL2)" certificate</b>	C20	✓	✓
<b>PROFIsafe certificate and protocol</b>	C21	✓	✓
<b>"Functional safety (SIL2/3)" certificate</b>	C23	✓	✓
<b>Setting of upper limit of output signal to 22.0 mA</b>	D05	✓	✓
<b>Manufacturer's declaration acc. to NACE</b> (only together with seal diaphragm made of Hastelloy and stainless steel)	D07	✓	✓
<b>Degree of protection IP68</b> (only for M20 x 1.5 and ½-14 NPT)	D12	✓	✓
<b>Process flange screws made of Monel</b>	D34	✓	✓
(max. nominal pressure PN20)			
<b>Supplied with oval flange set</b>	D37	✓	✓
(2 items), PTFE packings and screws in thread of process flanges			
<b>Use in or on zone 1D/2D</b> (only together with type of protection "Intrinsic safety (EEx ia)")	E01	✓	✓
<b>TÜV approval to AD/TRD</b> (only together with type of protection "Intrinsic safety (EEx ia)")	E06	✓	✓

Selection and Ordering data	Order code		
<i>Further designs</i>	HART	PA	FF
Add "-Z" to Order No. and specify Order Code.			
<b>Overfilling safety device for flammable and non-flammable liquids</b> (max. PN 32 (MVWP 464 psi), basic device with type of protection "Intrinsic safety (EEx ia)", to WHG and VbF, not together with measuring cell filling "inert liquid")	E08	✓	✓
<b>Oxygen application</b> (In the case of oxygen measurement and inert liquid max. 120 bar a (1740 psi a) at 60°C (140 °F))	E10	✓	✓
<b>Explosion-proof "Intrinsic safety" to INMETRO (Brazil)</b> (only for transmitter 7MF4...-.....-B..)	E25	✓	✓
<b>Ex Approval IEC Ex (EEx ia)</b> (only for transmitter 7MF4...-.....-B..)	E45	✓	✓
<b>Ex Approval IEC Ex (EEx id)</b> (only for transmitter 7MF4...-.....-D..)	E46	✓	✓
<b>Explosion-proof "Intrinsic safety" to NEPSI (China)</b> (only for transmitter 7MF4...-.....-B..)	E55	✓	✓
<b>Explosion protection "Explosion-proof" to NEPSI (China)</b> (only for transmitter 7MF4...-.....-D..)	E56	✓	✓
<b>Explosion-proof "Zone 2" to NEPSI (China)</b> (only for transmitter 7MF4...-.....-E..)	E57	✓	✓
<b>Two coats of lacquer on casing and cover (PU on epoxy)</b>	G10	✓	✓
<b>Interchanging of process connection side</b>	H01	✓	✓
<b>Vent on side for gas measurements</b>	H02	✓	✓
<b>Stainless steel process flanges for vertical differential pressure lines</b> (not together with K01, K02 and K04) <sup>3)</sup>	H03	✓	✓
<b>Process flange</b>			
• Hastelloy	K01	✓	✓
• Monel	K02	✓	✓
• Stainless steel with PVDF insert max. PN 10 (MWP 145 psi), max. temperature of medium 90 °C (194 °F)	K04	✓	✓

Factory mounting of valve manifolds, see accessories.

Supplementary electronics for 4-wire connection, see accessories.

For ½-14 NPT inner process connection on the side in the middle of the process flanges, vent valve not possible

✓ = available

<sup>1)</sup> When the manufacture's certificate (calibration certificate) has to be ordered for transmitters with diaphragm seals according to IEC 60770-2, it is recommended only to order this certificate exclusively with the diaphragm seals. The measuring accuracy of the total combination is certified here.

<sup>2)</sup> If the acceptance test certificate 3.1 is ordered for the transmitter with mounted diaphragm seals this certificate must also be ordered with the respective remote seals.

<sup>3)</sup> Not suitable for connection of remote seal

# Pressure Measurement

## Transmitters for general requirements

### SITRANS P DS III for differential pressure and flow

2

Selection and Ordering data	Order code		
<i>Additional data</i>	HART	PA	FF
Please add <b>"-Z"</b> to Order No. and specify Order code(s) and plain text.			
<b>Measuring range to be set</b> Specify in plain text:			
• in the case of linear characteristic curve (max. 5 characters): Y01: ... up to ... mbar, bar, kPa, MPa, psi	Y01	✓	
• in the case of square rooted characteristic (max. 5 characters): Y02: ... up to ... mbar, bar, kPa, MPa, psi	Y02	✓	
<b>Stainless steel tag plate (measuring point description)</b> Max. 16 char., specify in plain text: Y15: .....	Y15	✓	✓
<b>Measuring point text</b> Max. 27 char., specify in plain text: Y16: .....	Y16	✓	✓
<b>Entry of HART address (TAG)</b> Max. 8 char., specify in plain text: Y17: .....	Y17	✓	
<b>Setting of pressure indicator in pressure units</b> Specify in plain text (standard setting: bar): Y21: mbar, bar, kPa, MPa, psi, ... Note: The following pressure units can be selected: bar, mbar, mm H <sub>2</sub> O <sup>*</sup> , inH <sub>2</sub> O <sup>*</sup> , ftH <sub>2</sub> O <sup>*</sup> , mmHG, inHG, psi, Pa, kPa, MPa, g/cm <sup>2</sup> , kg/cm <sup>2</sup> , Torr, ATM or % *) ref. temperature 20 °C	Y21	✓	✓
<b>Setting of pressure indicator in non-pressure units<sup>1)</sup></b> Specify in plain text: Y22: ..... up to ..... l/min, m <sup>3</sup> /h, m, USgpm, ... (specification of measuring range in pressure units "Y01" or "Y02" is essential, unit with max. 5 characters)	Y22 2) + Y01 or Y02	✓	
<b>Preset bus address</b> possible between 1 and 126 Specify in plain text: Y25: .....	Y25		✓

Factory mounting of valve manifolds, see accessories.

Only "Y01", "Y21", "Y22", "Y25" and "D05" can be factory preset

✓ = available

<sup>1)</sup> Preset values can only be changed over SIMATIC PDM.

<sup>2)</sup> Not in conjunction with over-filling safety device for flammable and non-flammable liquids (Order Code "E08")

# Pressure Measurement

## Transmitters for general requirements

**SITRANS P DS III**  
 for differential pressure and flow

Selection and Ordering data		Order No.
<b>SITRANS P DS III HART pressure transmitters for differential pressure and flow, PN 420 (MWP 6092 psi)</b>		<b>7MF4533-</b>
<b>Measuring cell filling</b>	<b>Measuring cell cleaning</b>	
Silicone oil	normal	1
<b>Measuring span</b>		
2.5 ... 250 mbar	(1.004 ... 100.4 inH <sub>2</sub> O)	D
6 ... 600 mbar	(2.409 ... 240.9 inH <sub>2</sub> O)	E
16 ... 1600 mbar	(6.424 ... 642.4 inH <sub>2</sub> O)	F
50 ... 5000 mbar	(20.08 ... 2008 inH <sub>2</sub> O)	G
0.3 ... 30 bar	(4.35 ... 435 psi)	H
<b>Wetted parts materials</b>		
(stainless steel process flanges)		
Seal diaphragm	Parts of measuring cell	
Stainless steel	Stainless steel	A
Hastelloy	Stainless steel	B
Gold <sup>1)</sup>	Gold	L
Connection of remote seal possible on request		
<b>Process connection</b>		
Female thread 1/4-18 NPT with flange connection		
• Sealing screw opposite process connection		
- Mounting thread 7/16-20 UNF to EN 61518		3
- Mounting thread M12 to DIN 19213 (only for replacement requirement)		1
• Venting on side of process flanges, location of vent valve at top of process flanges (see dimensional drawing)		
- Mounting thread 7/16-20 UNF to EN 61518		7
- Mounting thread M12 to DIN 19213 (only for replacement requirement)		5
<b>Non-wetted parts materials</b>		
process flange screws	Electronics housing	
Stainless steel	Die-cast aluminum	2
Stainless steel	Stainless steel precision casting <sup>2)</sup>	3
<b>Version</b>		
• Standard versions		1
• International version, English label inscriptions, documentation in 5 languages on CD		2
<b>Explosion protection</b>		
• None		A
• With ATEX, Type of protection:		
- "Intrinsic safety (EEx ia)"		B
- "Explosion-proof (EEx d)" <sup>3)</sup>		D
- "Intrinsic safety and flameproof enclosure" (EEx ia + EEx d)" <sup>4)</sup>		P
- "Ex nA/nL (Zone 2)"		E
- "Intrinsic safety, explosion-proof enclosure and dust explosion protection (EEx ia+ EEx d + Zone 1D/2D)" <sup>4)</sup>		R
• With FM + CSA, Type of protection:		
- "Intrinsic safety and explosion-proof (is + xp)" <sup>3)</sup> , max PN 360		NC
<b>Electrical connection / cable entry</b>		
• Screwed gland Pg 13.5 <sup>5)</sup>		A
• Screwed gland M20x1.5		B
• Screwed gland 1/2-14 NPT		C
• Han 7D plug (plastic housing) incl. mating connector <sup>5)6)</sup>		D
• M12 connectors (metal) <sup>7)</sup>		F

Selection and Ordering data		Order No.
<b>SITRANS P DS III HART pressure transmitters for differential pressure and flow, PN 420 (MWP 6092 psi)</b>		<b>7MF4533-</b>
<b>Display</b>		
• Without indicator		0
• Without visible digital indicator (digital indicator concealed, setting: mA)		1
• With visible digital indication		6
• with customer-specific digital indicator (setting as specified, Order Code "Y21" or "Y22" required)		7
▶ Available ex stock		
Power supply units see Chap. 8 "Supplementary Components".		
Scope of delivery: Pressure transmitter as ordered (Instruction Manual is extra ordering item)		
1) Not in conjunction with max. span 600 mbar (240.9 inH <sub>2</sub> O)		
2) Not in conjunction with Electrical connection "Screwed gland Pg 13.5" and "Han7D plug".		
3) Without cable gland, with blanking plug		
4) With enclosed cable gland EEx ia and blanking plug		
5) Not in conjunction with types of protection "Explosion-proof" and "Ex nA", "Intrinsic safety" and "Explosion-proof".		
6) Permissible only for crimp-contact of conductor cross-section 1 mm <sup>2</sup>		
7) M12 delivered without cable socket		

# Pressure Measurement

## Transmitters for general requirements

### SITRANS P DS III for differential pressure and flow

2

Selection and Ordering data	Order No.
<b>Pressure transmitters for differential pressure and flow, PN 420 (MWP 6092 psi)</b>	
<b>SITRANS P DS III PA (PROFIBUS PA)</b>	7 MF 4 5 3 4 -
<b>SITRANS P DS III FF (FOUNDATION Fieldbus)</b>	7 MF 4 5 3 5 -
	1 ■■■■ - ■■■■
<b>Nominal measuring range</b>	
250 mbar (100.4 inH <sub>2</sub> O)	D
600 mbar (240.9 inH <sub>2</sub> O)	E
1600 mbar (642.4 inH <sub>2</sub> O)	F
5 bar (2008 inH <sub>2</sub> O)	G
30 bar (435 psi)	H
<b>Wetted parts materials</b> (stainless steel process flanges)	
Seal diaphragm Parts of measuring cell	
Stainless steel Stainless steel	A
Hastelloy Stainless steel	B
Gold <sup>1)</sup> Gold	L
Connection of remote seal possible on request	
<b>Process connection</b>	
Female thread 1/4-18 NPT with flange connection	
• Sealing screw opposite process connection	
- Mounting thread 7/16-20 UNF to EN 61518	3
- Mounting thread M12 to DIN 19213 (only for replacement requirement)	1
• Venting on side of process flanges, location of vent valve at top of process flanges (see dimensional drawing).	
- Mounting thread 7/16-20 UNF to EN 61518	7
- Mounting thread M12 to DIN 19213 (only for replacement requirement)	5
<b>Non-wetted parts materials</b>	
Process flange screws Electronics housing	
Stainless steel Die-cast aluminum	2
Stainless steel Stainless steel precision casting	3
<b>Version</b>	
• Standard versions	1
• International version, English label inscriptions, documentation in 5 languages on CD	2
<b>Explosion protection</b>	
• None	A
• With ATEX, Type of protection:	
- "Intrinsic safety (EEx ia)"	B
- "Explosion-proof (EEx d)" <sup>2)</sup>	D
- "Intrinsic safety and flameproof enclosure" (EEx ia + EEx d) <sup>3)</sup>	P
- "Ex nA/nL (Zone 2)"	E
- "Intrinsic safety, explosion-proof enclosure and dust explosion protection (EEx ia + EEx d + Zone 1D/2D)" <sup>3)</sup> (not for DS III FF)	R
• With FM + CSA, Type of protection:	
- "Intrinsic safety and explosion-proof (is + xp)" <sup>2)</sup> , max PN 360	NC
<b>Electrical connection / cable entry</b>	
• Screwed gland M20 x 1.5	B
• Screwed gland 1/2-14 NPT	C
• M12 connectors (metal) <sup>4)</sup>	F

Selection and Ordering data	Order No.
<b>Pressure transmitters for differential pressure and flow, PN 420 (MWP 6092 psi)</b>	
<b>SITRANS P DS III PA (PROFIBUS PA)</b>	7 MF 4 5 3 4 -
<b>SITRANS P DS III FF (FOUNDATION Fieldbus)</b>	7 MF 4 5 3 5 -
	1 ■■■■ - ■■■■
<b>Display</b>	
• Without (digital display hidden)	0
• Without visible digital indicator (digital indicator concealed, setting: mA)	1
• With visible digital indicator	6
• With customer-specific digital indicator (setting as specified, Order Code "Y21" required)	7
▶ Available ex stock	
Included in delivery of the device:	
• Brief instructions (Leporello)	
• CD-ROM with detailed documentation	
• Sealing plug(s) or sealing screw(s) for the process flange(s)	
1) Not in conjunction with max. span 600 mbar (240.9 inH <sub>2</sub> O)	
2) Without cable gland, with blanking plug.	
3) With enclosed cable gland EEx ia and blanking plug.	
4) M12 delivered without cable socket	

# Pressure Measurement

## Transmitters for general requirements

SITRANS P DS III  
for differential pressure and flow

2

Selection and Ordering data	Order code		
<i>Further designs</i>	HART	PA	FF
Add "-Z" to Order No. and specify Order Code.			
<b>Pressure transmitter with mounting bracket (2 shackles, 4 nuts, 4 U-plates, 1 angle) made of:</b>			
• Steel	A01	✓	✓
• Stainless steel	A02	✓	✓
<b>O-rings for process flanges</b> (instead of FPM (Viton))			
• PTFE (Teflon)	A20	✓	✓
• FEP (with silicone core, approved for food)	A21	✓	✓
• FFFM (Kalrez, compound 4079)	A22	✓	✓
• NBR (Buna N)	A23	✓	✓
<b>plug</b>			
• Han 7D (metal, gray)	A30	✓	
• Han 8U (instead of Han 7D)	A31	✓	
• Angled	A32	✓	
• Han 8D (metal, gray)	A33	✓	
<b>Sealing screws (2 unit(s))</b> ¼-18 NPT, with valve in mat. of process flanges	A40	✓	✓
<b>Cable sockets for M12 connectors (metal)</b>	A50	✓	✓
<b>Rating plate inscription</b> (instead of German)			
• English	B11	✓	✓
• French	B12	✓	✓
• Spanish	B13	✓	✓
• Italian	B14	✓	✓
<b>English rating plate</b> Pressure units in inH <sub>2</sub> O and/or psi	B21	✓	✓
<b>Quality inspection certificate (factory calibration) to IEC 60770-2</b>	C11	✓	✓
<b>Inspection certificate</b> Acc. to EN 10204-3.1	C12	✓	✓
<b>Factory certificate</b> Acc. to EN 10204-2.2	C14	✓	✓
<b>"Functional safety (SIL2)" certificate</b>	C20	✓	
<b>PROFIsafe certificate and protocol</b>	C21		✓
<b>"Functional safety (SIL2/3)" certificate</b>	C23	✓	
<b>Setting of upper limit of output signal to 22.0 mA</b>	D05	✓	
<b>Manufacturer's declaration acc. to NACE</b> (only together with seal diaphragm made of Hastelloy and stainless steel)	D07	✓	✓
<b>Degree of protection IP68</b> (only for M20 x 1.5 and ½-14 NPT)	D12	✓	✓
<b>Use in or on zone 1D/2D</b> (only together with type of protection "Intrinsic safety (EEx ia)")	E01	✓	✓
<b>Explosion-proof "Intrinsic safety" to INMETRO (Brazil)</b> (only for transmitter 7MF4...-.....-B..)	E25	✓	✓
<b>Ex Approval IEC Ex (EEx ia)</b> (only for transmitter 7MF4...-.....-B..)	E45	✓	✓
<b>Ex Approval IEC Ex (EEx id)</b> (only for transmitter 7MF4...-.....-D..)	E46	✓	✓

Selection and Ordering data	Order code		
<i>Further designs</i>	HART	PA	FF
Add "-Z" to Order No. and specify Order Code.			
<b>Explosion-proof "Intrinsic safety" to NEPSI (China)</b> (only for transmitter 7MF4...-.....-B..)	E55	✓	✓
<b>Explosion protection "Explosion-proof" to NEPSI (China)</b> (only for transmitter 7MF4...-.....-D..)	E56	✓	✓
<b>Explosion-proof "Zone 2" to NEPSI (China)</b> (only for transmitter 7MF4...-.....-E..)	E57	✓	✓
<b>Two coats of lacquer on casing and cover (PU on epoxy)</b>	G10	✓	✓
<b>Interchanging of process connection side</b>	H01	✓	✓
<b>Stainless steel process flanges for vertical differential pressure lines</b>	H03	✓	✓
<b>Additional data</b>			
Please add "-Z" to Order No. and specify Order code(s) and plain text.			
<b>Measuring range to be set</b> Specify in plain text:			
• in the case of linear characteristic curve (max. 5 characters): Y01: ... up to ... mbar, bar, kPa, MPa, psi	Y01	✓	
• in the case of square rooted characteristic curve (max. 5 characters): Y02: ... up to ... mbar, bar, kPa, MPa, psi	Y02	✓	
<b>Stainless steel tag plate (measuring point description)</b> Max. 16 characters, specify in plain text: Y15: .....	Y15	✓	✓
<b>Measuring point text</b> Max. 27 characters, specify in plain text: Y16: .....	Y16	✓	✓
<b>Entry of HART address (TAG)</b> Max. 8 characters, specify in plain text: Y17: .....	Y17	✓	
<b>Setting of pressure indication in pressure units</b> Specify in plain text (standard setting: bar): Y21: mbar, bar, kPa, MPa, psi, ... Note: The following pressure units can be selected: bar, mbar, mm H <sub>2</sub> O <sup>1)</sup> , inH <sub>2</sub> O <sup>1)</sup> , ftH <sub>2</sub> O <sup>1)</sup> , mmHG, inHG, psi, Pa, kPa, MPa, g/cm <sup>2</sup> , kg/cm <sup>2</sup> , Torr, ATM or % ) ref. temperature 20 °C	Y21	✓	✓
<b>Setting of pressure indication in non-pressure units<sup>1)</sup></b> Specify in plain text: Y22: .... up to .... l/min, m <sup>3</sup> /h, m, USgpm, ... (specification of measuring range in pressure units "Y01" or "Y02" is essential, unit with max. 5 characters)	Y22 + Y01 or Y02	✓	
<b>Preset bus address</b> possible between 1 and 126 Specify in plain text: Y25: .....	Y25		✓
Factory mounting of valve manifolds, see accessories. Only "Y01", "Y21", "Y22", "Y25" and "D05" can be factory preset. ✓ = available			

<sup>1)</sup> Preset values can only be changed over SIMATIC PDM.

# Pressure Measurement

## Transmitters for general requirements

SITRANS P DS III  
for differential pressure and flow

### Dimensional drawings

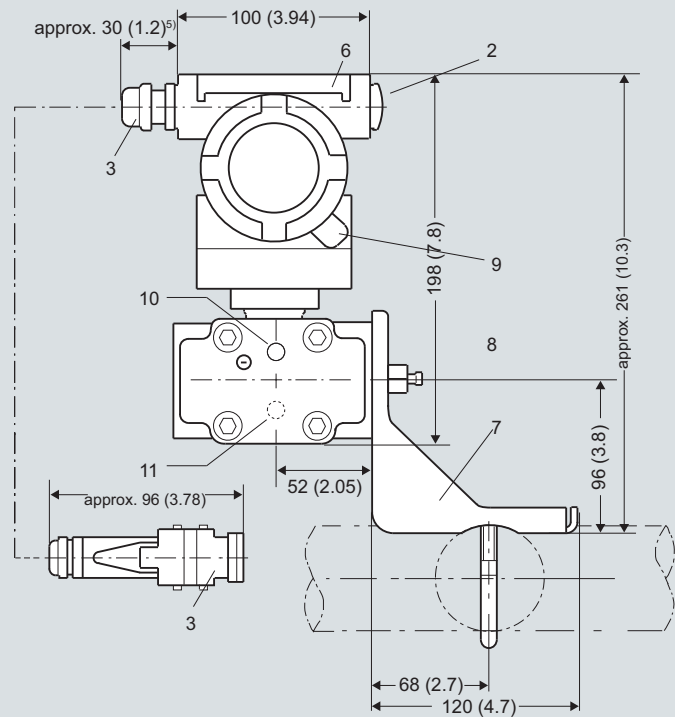
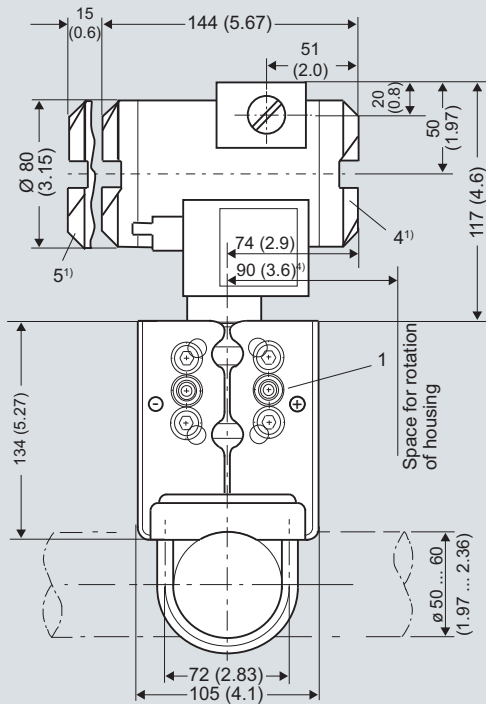

- 1 Process connection: 1/4-18 NPT (EN 61518)
- 2 Blanking plug
- 3 Electrical connection:
  - Screwed gland Pg 13,5 (adapter)<sup>2)3)</sup>, only DS III HART,
  - Screwed gland M20x1,5<sup>3)</sup>,
  - Screwed gland 1/2-14 NPT,
  - Han 7D/Han 8D<sup>2)3)</sup> plug, only DS III HART, or
  - M12 connector
- 4 Terminal side
- 5 Electronics side, digital display (longer overall length for cover with window)
- 6 Protective cover over keys
- 7 Mounting bracket (option)
- 8 Sealing screw with valve (option)
- 9 Screw cover - safety bracket (only for type of protection "Explosion-proof enclosure", not shown in the drawing)
- 10 Lateral venting for liquid measurement (Standard)
- 11 Lateral venting for gas measurement (suffix H02)

- 1) Allow approx. 20 mm (0.79 inch) thread length to permit unscrewing
- 2) Not with type of protection "explosion-proof enclosure"
- 3) Not with type of protection "FM + CSA [is + xp]"
- 4) 92 mm (3.62 inch) for minimum distance to permit rotation with indicator
- 5) 45 mm (1.8 inch) for Pg 13,5 with adapter

SITRANS P DS III pressure transmitters for differential pressure and flow, dimensions in mm (inch)

# Pressure Measurement

## Transmitters for general requirements

SITRANS P DS III  
for differential pressure and flow

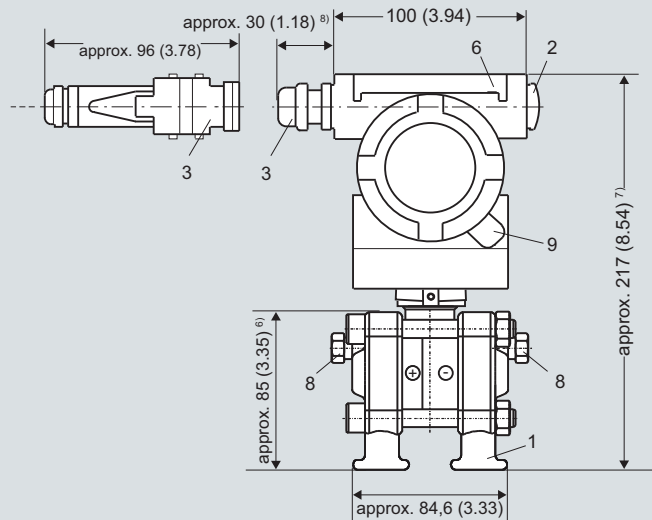
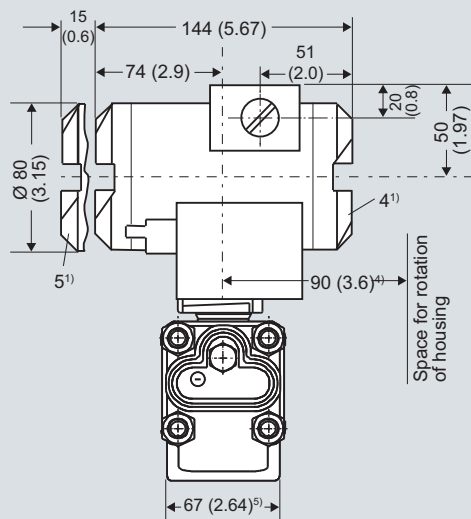

- 1 Process connection: 1/4-18 NPT (EN 61518)
- 2 Blanking plug
- 3 Electrical connection:
  - Screwed gland Pg 13,5 (adapter)<sup>2)3)</sup>, only DS III HART,
  - Screwed gland M20x1,5<sup>3)</sup>,
  - Screwed gland 1/2-14 NPT,
  - Han 7D/Han 8D<sup>2)3)</sup> plug, only DS III HART, or
  - M12 connector
- 4 Terminal side
- 5 Electronics side, digital display (longer overall length for cover with window)
- 6 Protective cover over keys
- 7 Mounting bracket (option)
- 8 Sealing screw with valve (option)
- 9 Screw cover - safety bracket (only for type of protection "Explosion-proof enclosure", not shown in the drawing)

- 1) Allow approx. 20 mm (0.79 inch) thread length to permit unscrewing
- 2) Not with type of protection "explosion-proof enclosure"
- 3) Not with type of protection "FM + CSA [is + xp]"
- 4) 92 mm (3.6 inch) for minimum distance to permit rotation with indicator
- 5) 74 mm (2.9 inch) for PN ≤ 420 (MWP ≤ 6092 psi)
- 6) 91 mm (3.6 inch) for PN ≤ 420 (MWP ≤ 6092 psi)
- 7) 219 mm (8.62 inch) for PN ≤ 420 (MWP ≤ 6092 psi)
- 8) 45 mm (1.8 inch) for Pg 13,5 with adapter

SITRANS P DS III pressure transmitters for differential pressure and flow, with process covers for vertical differential pressure lines, optional "H03", dimensional drawing, dimensions in mm (inch)



SITRANS P DS III pressure transmitters for differential pressure and flow, with process covers for vertical differential pressure lines

# Pressure Measurement

## Transmitters for general requirements

### SITRANS P DS III for level

#### Technical specifications

SITRANS P DS III for level		HART		PROFIBUS PA or FOUNDATION Fieldbus	
<b>Input</b>		Level			
Measured variable		Span	Maximum operating pressure	Nominal measuring range	Maximum operating pressure
Spans (infinitely adjustable) or nominal measuring range and max. permissible operating pressure		25 ... 250 mbar (0.36 ... 3.63 psi)	See "Mounting flange"	250 mbar (3.63 psi)	See "Mounting flange"
		25 ... 600 mbar (0.36 ... 8.7 psi)	See "Mounting flange"	600 mbar (8.7 psi)	See "Mounting flange"
		53 ... 1600 mbar (0.77 ... 23.2 psi)	See "Mounting flange"	1600 mbar (23.2 psi)	See "Mounting flange"
		160 ... 5000 mbar (2.32 ... 72.5 psi)	See "Mounting flange"	5000 mbar (72.5 psi)	See "Mounting flange"
Lower measuring limit		-100 % of max. span or 30 mbar (0.435 psi a), depending on mounting flange			
• Measuring cell with silicone oil filling					
Upper measuring limit		100 % of max. span		100 % of the max. nominal measuring range	
<b>Output</b>					
Output signal		4 ... 20 mA		Digital PROFIBUS PA and FOUNDATION Fieldbus signal	
• Lower limit (infinitely adjustable)		3.55 mA, factory preset to 3.84 mA		-	
• Upper limit (infinitely adjustable)		23 mA, factory preset to 20.5 mA or optionally set to 22.0 mA		-	
Load					
• Without HART communication		$R_B \leq (U_H - 10.5 \text{ V})/0.023 \text{ A}$ in $\Omega$ , $U_H$ : Power supply in V		-	
• With HART communication		$R_B = 230 \dots 500 \Omega$ (SIMATIC PDM) or $R_B = 230 \dots 1100 \Omega$ (HART Communicator)		-	
Physical bus		-		IEC 61158-2	
Protection against polarity reversal		Protected against short-circuit and polarity reversal. Each connection against the other with max. supply voltage.			
<b>Measuring accuracy</b>		Acc. to EN 60770-1			
Reference conditions (All error data refer always refer to the set span)		Increasing characteristic, start-of-scale value 0 bar, stainless steel seal diaphragm, silicone oil filling, room temperature 25 °C (77 °F) r: Span ratio (r = max. span / set span)			
Error in measurement and fixed-point setting (including hysteresis and repeatability)					
• Linear characteristic				≤ 0.15 %	
- r ≤ 10		≤ 0.15 %			
- 10 < r ≤ 30		≤ 0.3 %			
- 30 < r ≤ 100		≤ (0.0075 · r + 0.075) %			
Long-term drift (temperature change ± 30 °C (± 54 °F))		≤ (0.25 · r) % every 5 years static pressure max. 70 bar g (1015 psi g)		≤ 0.25 % every 5 years static pressure max. 70 bar g (1015 psi g)	
Influence of ambient temperature					
• at -10 ... +60 °C (14 ... 140 °F)					
- 250-mbar (3.63 psi) measuring cell		≤ (0.5 · r + 0.2) % (0.4 in place of 0.2 at 10 < r ≤ 30)		≤ 0.7 %	
- 600-mbar (8.7 psi) measuring cell		≤ (0.3 · r + 0.2) % (0.4 in place of 0.2 at 10 < r ≤ 30)		≤ 0.5 %	
- 1600 and 5000 mbar (23.2 and 72.5 psi) measuring cells		≤ (0.25 · r + 0.2) % (0.4 in place of 0.2 at 10 < r ≤ 30)		≤ 0.45 %	
• at -40 ... -10 °C and 60 ... 85 °C (-40 ... +14 °F and 140 ... 185 °F)					
- 250-mbar (3.63 psi) measuring cell		≤ (0.25 · r + 0.15) %/10 K doubled values at 10 < r ≤ 30		≤ 0.4 %/10 K	
- 600-mbar (8.7 psi) measuring cell		≤ (0.15 · r + 0.15) %/10 K doubled values at 10 < r ≤ 30		≤ 0.3 %/10 K	
- 1600 and 5000 mbar (23.2 and 72.5 psi) measuring cells		≤ (0.12 · r + 0.15) %/10 K double values at 10 < r ≤ 30		≤ 0.27 %/10 K	

# Pressure Measurement

## Transmitters for general requirements

**SITRANS P DS III**  
 for level

2

SITRANS P DS III for level	HART	PROFIBUS PA or FOUNDATION Fieldbus
Influence of static pressure		
<ul style="list-style-type: none"> <li>on the zero point               <ul style="list-style-type: none"> <li>- 250-mbar (3.63 psi) measuring cell</li> <li>- 600-mbar (8.7 psi) measuring cell</li> <li>- 1600 and 5000 mbar (23.2 and 72.5 psi) measuring cells</li> </ul> </li> <li>on the span</li> </ul>	$\leq (0.3 \cdot r) \% \text{ per nominal pressure}$ $\leq (0.15 \cdot r) \% \text{ per nominal pressure}$ $\leq (0.1 \cdot r) \% \text{ per nominal pressure}$ $\leq (0.1 \cdot r) \% \text{ per nominal pressure}$	$\leq 0.3 \% \text{ per nominal pressure}$ $\leq 0.15 \% \text{ per nominal pressure}$ $\leq 0.1 \% \text{ per nominal pressure}$ $\leq 0.1 \% \text{ per nominal pressure}$
Measured Value Resolution	-	$3 \cdot 10^{-5}$ of nominal measuring range
<b>Rated conditions</b>	IP65	
Degree of protection (to EN 60529)	IP65	
Temperature of medium	<b>Note:</b> Always take into account assignment of max. permissible operating temperature to max. permissible operating pressure of the respective flange connection!	
<ul style="list-style-type: none"> <li>Measuring cell with silicone oil filling               <ul style="list-style-type: none"> <li>- High-pressure side</li> <li>- Low-pressure side</li> </ul> </li> </ul>	$-40 \dots +100 \text{ }^\circ\text{C} (-40 \dots +212 \text{ }^\circ\text{F})$ $p_{\text{abs}} \geq 1 \text{ bar: } -40 \dots +175 \text{ }^\circ\text{C} (-40 \dots +347 \text{ }^\circ\text{F})$ $p_{\text{abs}} < 1 \text{ bar: } -40 \dots +80 \text{ }^\circ\text{C} (-40 \dots +176 \text{ }^\circ\text{F})$ $-40 \dots +100 \text{ }^\circ\text{C} (-40 \dots +212 \text{ }^\circ\text{F})$ $-20 \dots +60 \text{ }^\circ\text{C} (-4 \dots +140 \text{ }^\circ\text{F})$ in conjunction with dust explosion protection	
Ambient conditions		
<ul style="list-style-type: none"> <li>Ambient temperature               <ul style="list-style-type: none"> <li>- Digital indicator</li> </ul> </li> <li>Storage temperature</li> <li>Climatic class               <ul style="list-style-type: none"> <li>- Condensation</li> </ul> </li> </ul>	$-30 \dots +85 \text{ }^\circ\text{C} (-22 \dots +185 \text{ }^\circ\text{F})$ $-50 \dots +85 \text{ }^\circ\text{C} (-58 \dots +185 \text{ }^\circ\text{F})$ Relative humidity 0 ... 100 % Condensation permissible, suitable for use in the tropics	
<ul style="list-style-type: none"> <li>Electromagnetic Compatibility               <ul style="list-style-type: none"> <li>- Emitted interference and interference immunity</li> </ul> </li> </ul>	Acc. to EN 61326 and NAMUR NE 21	
<b>Design</b>		
Weight (without options)		
To EN (pressure transmitter with mounting flange, without tube)	$\approx 11 \dots 13 \text{ kg} (\approx 24.2 \dots 28.7 \text{ lb})$	
To ASME (pressure transmitter with mounting flange, without tube)	$\approx 11 \dots 18 \text{ kg} (\approx 24.2 \dots 39.7 \text{ lb})$	
Enclosure material	Low-copper die-cast aluminum, GD-AlSi12 or stainless steel precision casting, mat. no. 1.4408	
Wetted parts materials		
High-pressure side		
<ul style="list-style-type: none"> <li>Seal diaphragm of mounting flange</li> </ul>	Stainless steel, mat. no. 1.4404/316L, Monel, mat. no. 2.4360, Hastelloy B2, mat. no. 2.4617, Hastelloy C276, mat. no. 2.4819, Hastelloy C4, mat. no. 2.4610, tantalum, PTFE, ETCFE	
Measuring cell filling	Silicone oil	
Process connection		
<ul style="list-style-type: none"> <li>High-pressure side</li> <li>Low-pressure side</li> </ul>	Flange to EN and ASME Female thread $\frac{1}{4}$ -18 NPT and flange connection with mounting thread M10 to DIN 19213 or $\frac{7}{16}$ -20 UNF to EN 61518	
<b>Power supply <math>U_H</math></b>		
Terminal voltage on transmitter	10.5 ... 45 V DC 10.5 ... 30 V DC in intrinsically-safe mode	Supplied through bus -
Separate 24 V power supply necessary	-	No
Bus voltage		
<ul style="list-style-type: none"> <li>Not Ex</li> </ul>	-	9 ... 32 V
<ul style="list-style-type: none"> <li>With intrinsically-safe operation</li> </ul>	-	9 ... 24 V
Current consumption		
<ul style="list-style-type: none"> <li>Basic current (max.)</li> </ul>	-	12.5 mA
<ul style="list-style-type: none"> <li>Start-up current <math>\leq</math> basic current</li> </ul>	-	Yes
<ul style="list-style-type: none"> <li>Max. current in event of fault</li> </ul>	-	15.5 mA
Fault disconnection electronics (FDE) available	-	Yes

# Pressure Measurement

## Transmitters for general requirements

### SITRANS P DS III for level

2

SITRANS P DS III for level	HART	PROFIBUS PA or FOUNDATION Fieldbus
<b>Certificates and approvals</b>		
Classification according to PED 97/23/EC	For gases of fluid group 1 and liquids of fluid group 1; complies with requirements of article 3, paragraph 3 (sound engineering practice)	
Explosion protection		
• Intrinsic safety "i"	PTB 99 ATEX 2122	
- Marking	Ex II 1/2 G EEx ia/ib IIB/IIC T6	
- Permissible ambient temperature	-40 ... +85 °C (-40 ... +185 °F) temperature class T4; -40 ... +70 °C (-40 ... +158 °F) temperature class T5; -40 ... +60 °C (-40 ... +140 °F) temperature class T6	
- Connection	To certified intrinsically-safe circuits with peak values: $U_i = 30 \text{ V}$ , $I_i = 100 \text{ mA}$ , $P_i = 750 \text{ mW}$ ; $R_i = 300 \Omega$	FISCO supply unit: $U_o = 17.5 \text{ V}$ , $I_o = 380 \text{ mA}$ , $P_o = 5.32 \text{ W}$ Linear barrier: $U_o = 24 \text{ V}$ , $I_o = 250 \text{ mA}$ , $P_o = 1.2 \text{ W}$
- Effective internal inductance/capacitance	$L_i = 0.4 \text{ mH}$ , $C_i = 6 \text{ nF}$	$L_i = 7 \mu\text{H}$ , $C_i = 1.1 \text{ nF}$
• Explosion-proof "d"	PTB 99 ATEX 1160	
- Marking	Ex II 1/2 G EEx d IIC T4/T6	
- Permissible ambient temperature	-40 ... +85 °C (-40 ... +185 °F) temperature class T4; -40 ... +60 °C (-40 ... +140 °F) temperature class T6	
- Connection	To circuits with values: $U_H = 10.5 \dots 45 \text{ V DC}$	To circuits with values: $U_H = 9 \dots 32 \text{ V DC}$
• Dust explosion protection for zone 20	PTB 01 ATEX 2055	
- Marking	Ex II 1 D IP65 T 120 °C Ex II 1/2 D IP65 T 120 °C	
- Permissible ambient temperature	-40 ... +85 °C (-40 ... +185 °F)	
- Max. surface temperature	120 °C (248 °F)	
- Connection	To certified intrinsically-safe circuits with peak values: $U_i = 30 \text{ V}$ , $I_i = 100 \text{ mA}$ , $P_i = 750 \text{ mW}$ , $R_i = 300 \Omega$	FISCO supply unit: $U_o = 17.5 \text{ V}$ , $I_o = 380 \text{ mA}$ , $P_o = 5.32 \text{ W}$ Linear barrier: $U_o = 24 \text{ V}$ , $I_o = 250 \text{ mA}$ , $P_o = 1.2 \text{ W}$
- Effective internal inductance/capacitance	$L_i = 0.4 \text{ mH}$ , $C_i = 6 \text{ nF}$	$L_i = 7 \mu\text{H}$ , $C_i = 1.1 \text{ nF}$
• Dust explosion protection for zone 21/22	PTB 01 ATEX 2055	
- Marking	Ex II 2 D IP65 T 120 °C	
- Connection	To circuits with values: $U_H = 10.5 \dots 45 \text{ V DC}$ ; $P_{\max} = 1.2 \text{ W}$	To circuits with values: $U_H = 9 \dots 32 \text{ V DC}$ ; $P_{\max} = 1.2 \text{ W}$
• Type of protection "n" (zone 2)	TÜV 01 ATEX 1696 X	
- Marking	Ex II 3 G EEx nA L IIC T4/T5/T6	
• Explosion protection acc. to FM	Certificate of Compliance 3008490	
- Identification (XP/DIP) or (IS); (NI)	CL I, DIV 1, GP ABCD T4...T6; CL II, DIV 1, GP EFG; CL III; CL I, ZN 0/1 AEx ia IIC T4...T6; CL I, DIV 2, GP ABCD T4...T6; CL II, DIV 2, GP FG; CL III	
• Explosion protection to CSA	Certificate of Compliance 1153651	
- Identification (XP/DIP) or (IS)	CL I, DIV 1, GP ABCD T4...T6; CL II, DIV 1, GP EFG; CL III; Ex ia IIC T4...T6; CL I, DIV 2, GP ABCD T4...T6; CL II, DIV 2, GP FG; CL III	

# Pressure Measurement

## Transmitters for general requirements

**SITRANS P DS III**  
**for level**

2

<b>HART communication</b>		<b>FOUNDATION Fieldbus communication</b>	
HART communication	230 ... 1100 Ω	Function blocks	3 function blocks analog input, 1 function block PID
Protocol	HART Version 5.x	• Analog input	Yes, linearly rising or falling characteristic
Software for computer	SIMATIC PDM	- Adaptation to customer-specific process variables	0 ... 100 s
<b>PROFIBUS PA communication</b>		- Electrical damping $T_{63}$ , adjustable	Output/input (can be locked within the device with a bridge)
Simultaneous communication with master class 2 (max.)	4	- Simulation function	parameterizable (last good value, substitute value, incorrect value)
The address can be set using	Configuration tool or local operation (standard setting address 126)	- Failure mode	Yes, one upper and lower warning limit and one alarm limit respectively
Cyclic data usage		- Limit monitoring	Yes
• Output byte	5 (one measured value) or 10 (two measured values)	- Square-rooted characteristic for flow measurement	Standard FF function block
• Input byte	0, 1, or 2 (register operating mode and reset function for metering)	• PID	1 resource block
Internal preprocessing		• Physical block	1 transducer block Pressure with calibration, 1 transducer block LCD
Device profile	PROFIBUS PA Profile for Process Control Devices Version 3.0, Class B	Transducer blocks	
Function blocks	2	• Pressure transducer block	
• Analog input		- Can be calibrated by applying two pressures	Yes
- Adaptation to customer-specific process variables	Yes, linearly rising or falling characteristic	- Monitoring of sensor limits	Yes
- Electrical damping $T_{63}$ , adjustable	0 ... 100 s	- Simulation function: Measured pressure value, sensor temperature and electronics temperature	Constant value or over parameterizable ramp function
- Simulation function	Input/Output		
- Failure mode	parameterizable (last good value, substitute value, incorrect value)		
- Limit monitoring	Yes, one upper and lower warning limit and one alarm limit respectively		
• Register (totalizer)	Can be reset, preset, optional direction of counting, simulation function of register output	<b>Mounting flange</b>	
- Failure mode	parameterizable (summation with last good value, continuous summation, summation with incorrect value)	Nominal diameter	Nominal pressure
- Limit monitoring	One upper and lower warning limit and one alarm limit respectively	• Acc. to EN 1092-1	
• Physical block	1	- DN 80	PN 40
Transducer blocks	2	- DN100	PN16, PN40
• Pressure transducer block		• To ASME B16.5	
- Can be calibrated by applying two pressures	Yes	- 3 inch	Class 150, class 300
- Monitoring of sensor limits	Yes	- 4 inch	Class 150, class 300
- Specification of a container characteristic with	Max. 30 nodes		
- Square-rooted characteristic for flow measurement	Yes		
- Gradual volume suppression and implementation point of square-root extraction	Parameterizable		
- Simulation function for measured pressure value and sensor temperature	Constant value or over parameterizable ramp function		

# Pressure Measurement

## Transmitters for general requirements

### SITRANS P DS III for level

2

Selection and Ordering data		Order No.
<b>Pressure transmitter for level, SITRANS P DS III HART</b>		<b>7MF4633 -</b>
<b>Measuring cell filling</b>	<b>Measuring cell cleaning</b>	<b>Y - - - -</b>
Silicone oil	normal	<b>1</b>
<b>Measuring span</b>		
25 ... 250 mbar	(0.363 ... 3.63 psi)	<b>D</b>
25 ... 600 mbar	(0.363 ... 8.70 psi)	<b>E</b>
53 ... 1600 mbar	(0.77 ... 23.2 psi)	<b>F</b>
0.16 ... 5 bar	(2.32 ... 72.5 psi)	<b>G</b>
<b>Process connection of low-pressure side</b>		
Female thread 1/4-18 NPT with flange connection		
• Mounting thread 7/16-20 UNF to EN 61518		<b>2</b>
• Mounting thread M10 to DIN 19213 (only for replacement requirement)		<b>0</b>
<b>Non-wetted parts materials</b>		
process flange screws	Electronics housing	
Stainless steel	Die-cast aluminum	<b>2</b>
Stainless steel	Stainless steel precision casting <sup>1)</sup>	<b>3</b>
<b>Version</b>		
• Standard versions		<b>1</b>
• International version, English label inscriptions, documentation in 5 languages on CD		<b>2</b>
<b>Explosion protection</b>		
• None		<b>A</b>
• With ATEX, Type of protection:		
- "Intrinsic safety (EEx ia)"		<b>B</b>
- "Explosion-proof (EEx d)" <sup>2)</sup>		<b>D</b>
- "Intrinsic safety and flameproof enclosure" (EEx ia + EEx d)" <sup>3)</sup>		<b>P</b>
- "Ex nA/nL (Zone 2)"		<b>E</b>
- "Intrinsic safety, explosion-proof enclosure and dust explosion protection (EEx ia+ EEx d + Zone 1D/2D)" <sup>3)</sup>		<b>R</b>
• With FM + CSA, Type of protection:		
- "Intrinsic Safe und Explosion Proof (is + xp)" <sup>4)</sup>		<b>NC</b>
<b>Electrical connection / cable entry</b>		
• Screwed gland Pg 13.5 <sup>4)</sup>		<b>A</b>
• Screwed gland M20x1.5		<b>B</b>
• Screwed gland 1/2-14 NPT		<b>C</b>
• Han 7D plug (plastic housing) incl. mating connector <sup>4)</sup>		<b>D</b>
• M12 connectors (metal) <sup>5)</sup>		<b>F</b>
<b>Display</b>		
• Without indicator		<b>0</b>
• Without visible digital indicator (digital indicator ► concealed, setting: mA)		<b>1</b>
• With visible digital indication		<b>6</b>
• With customer-specific digital indicator (setting as specified, Order Code "Y21" or "Y22" re- quired)		<b>7</b>

► Available ex stock

**Ordering information**

1st order item: Pressure transmitter 7MF4633-...

2nd order item: Mounting flange 7MF4912-3...

**ordering example**

Item line 1: 7MF4633-1EY20-1AA1-Z  
 B line: Y01  
 C line: Y01: 80 to 143 mbar (1.16 to 2.1 psi)  
 Item line 2: 7MF4912-3GE01

Power supply units see Chap. 8 "Supplementary Components".

Included in delivery of the device:

- Brief instructions (Leporello)
- CD-ROM with detailed documentation
- Sealing plug(s) or sealing screw(s) for the process flanges(s)

- 1) Not in conjunction with electrical connection "Screwed gland Pg 13.5" and "Han7D plug".
- 2) Without cable gland, with blanking plug.
- 3) With enclosed cable gland EEx ia and blanking plug.
- 4) Not in conjunction with types of protection "Explosion-proof" and "Ex nA", "Intrinsic safety" and "Explosion-proof".
- 5) M12 delivered without cable socket

# Pressure Measurement

## Transmitters for general requirements

SITRANS P DS III  
for level

2

Selection and Ordering data	Order No.
<b>Pressure transmitters for level</b>	
<b>SITRANS P DS III PA (PROFIBUS PA)</b>	7MF4634 -
<b>SITRANS P DS III FF (FOUNDATION Fieldbus)</b>	7MF4635 -
	1 Y -
<b>Nominal measuring range</b>	
250 mbar (3.63 psi)	D
600 mbar (8.70 psi)	E
1600 mbar (23.2 psi)	F
5 bar (72.5 psi)	G
<b>Process connection of low-pressure side</b>	
Female thread 1/4-18 NPT with flange connection	
• Mounting thread 7/16-20 UNF to EN 61518	2
• Mounting thread M10 to DIN 19213 (only for replacement requirement)	0
<b>Non-wetted parts materials</b>	
process flange screws Electronics housing	
Stainless steel Die-cast aluminum	2
Stainless steel Stainless steel precision casting	3
<b>Version</b>	
• Standard versions	1
• International version, English label inscriptions, documentation in 5 languages on CD	2
<b>Explosion protection</b>	
• None	A
• With ATEX, Type of protection:	
- "Intrinsic safety (EEx ia)"	B
- "Explosion-proof (EEx <sup>1</sup> d)"	D
- "Intrinsic safety and flameproof enclosure" (EEx ia + EEx d) <sup>2</sup>	P
- "Ex nA/nL (Zone 2)"	E
- "Intrinsic safety, explosion-proof enclosure and dust explosion protection (EEx ia + EEx d + Zone 1D/2D) <sup>2</sup> " (not for DS III FF)	R
• With FM + CSA, Type of protection:	
- "Intrinsic Safe und Explosion Proof (is + xp) <sup>1</sup> "	NC
<b>Electrical connection / cable entry</b>	
• Screwed gland M20 x 1.5	B
• Screwed gland 1/2-14 NPT	C
• M12 connectors (metal) <sup>3</sup>	F
<b>Display</b>	
• Without indicator	0
• Without visible digital indicator(digital indicator ► concealed, setting: mA)	1
• With visible digital indication	6
• With customer-specific digital indication (setting as specified, Order Code "Y21" required)	7

► Available ex stock

### Ordering information

1st order item: Pressure transmitter 7MF4634-...

2nd order item: Mounting flange 7MF4912-...

### ordering example

Item line 1: 7MF4634-1EY20-1AA1

Item line 2: 7MF4912-3GE01

Included in delivery of the device:

- Brief instructions (Leporello)
- CD-ROM with detailed documentation
- Sealing plug(s) or sealing screw(s) for the process flanges(s)

<sup>1</sup>) Without cable gland, with blanking plug.

<sup>2</sup>) With enclosed cable gland EEx ia and blanking plug.

<sup>3</sup>) M12 delivered without cable socket

# Pressure Measurement

## Transmitters for general requirements

### SITRANS P DS III for level

2

Selection and Ordering data	Order code		
<i>Further designs</i>	HART	PA	FF
Add "-Z" to Order No. and specify Order Code.			
<b>O-rings for process flanges on low-pressure side</b> (instead of FPM (Viton))			
• PTFE (Teflon)	A20	✓	✓
• FEP (with silicone core, approved for food)	A21	✓	✓
• FFPM (Kalrez, compound 4079)	A22	✓	✓
• NBR (Buna N)	A23	✓	✓
<b>Plug</b>			
• Han 7D (metal, gray)	A30	✓	
• Han 8U (instead of Han 7D)	A31	✓	
• Angled	A32	✓	
• Han 8D (metal, gray)	A33	✓	
<b>Sealing screw</b>			
¼-18 NPT, with valve in mat. of process flanges	A40	✓	✓
<b>Cable sockets for M12 connectors (metal)</b>	A50	✓	✓
<b>Rating plate inscription</b> (instead of German)			
• English	B11	✓	✓
• French	B12	✓	✓
• Spanish	B13	✓	✓
• Italian	B14	✓	✓
<b>English rating plate</b>	B21	✓	✓
Pressure units in inH <sub>2</sub> O and/or psi			
<b>Quality inspection certificate (factory calibration) to IEC 60770-2</b>	C11	✓	✓
<b>Inspection certificate</b>	C12	✓	✓
Acc. to EN 10204-3.1			
<b>Factory certificate</b>	C14	✓	✓
Acc. to EN 10204-2.2			
<b>"Functional safety (SIL2)" certificate</b>	C20	✓	
<b>PROFIsafe certificate and protocol</b>	C21		✓
<b>"Functional safety (SIL2/3)" certificate</b>	C23	✓	
<b>Setting of upper limit of output signal to 22.0 mA</b>	D05	✓	
<b>Degree of protection IP68</b> (only for M20x1.5 and ½-14 NPT)	D12	✓	✓
<b>Supplied with oval flange</b> (1 item), PTFE packing and screws in thread of process flange	D37	✓	✓
<b>Use on zone 1D / 2D</b> (only together with type of protection "Intrinsic safety (EEx ia)")	E01	✓	✓
<b>Overfilling safety device for flammable and non-flammable liquids</b> (max. PN 32 (MVWP 464 psi), basic device with type of protection "Intrinsic safety (EEx ia)")	E08	✓	✓
<b>Explosion-proof "Intrinsic safety" to INMETRO (Brazil)</b> (only for transmitter 7MF4...-.....-B..)	E25	✓	✓
<b>Ex Approval IEC Ex (EEx ia)</b> (only for transmitter 7MF4...-.....-B..)	E45	✓	✓
<b>Ex Approval IEC Ex (EEx id)</b> (only for transmitter 7MF4...-.....-D..)	E46	✓	✓

Selection and Ordering data	Order code		
<i>Further designs</i>	HART	PA	FF
Add "-Z" to Order No. and specify Order Code.			
<b>Explosion-proof "Intrinsic safety" to NEPSI (China)</b> (only for transmitter 7MF4...-.....-B..)	E55	✓	✓
<b>Explosion protection "Explosion-proof" to NEPSI (China)</b>  (only for transmitter 7MF4...-.....-D..)	E56	✓	✓
<b>Ex protection "Zone 2" to NEPSI (China)</b> (only for transmitter 7MF4...-.....-E..)	E57	✓	✓
<b>Two coats of lacquer on casing and cover (PU on epoxy)</b>	G10	✓	✓
<b>Replacement of process connection side</b>	H01	✓	✓
<b>Additional data</b>			
Please add "-Z" to Order No. and specify Order code(s) and plain text.			
<b>Measuring range to be set</b> Specify in plain text (max. 5 characters): Y01: ... up to ... mbar, bar, kPa, MPa, psi	Y01	✓	
<b>Stainless steel tag plate (measuring point description)</b> Max. 16 characters, specify in plain text: Y15: .....	Y15	✓	✓
<b>Measuring point text</b> Max. 27 characters, specify in plain text: Y16: .....	Y16	✓	✓
<b>Entry of HART address (TAG)</b> Max. 8 characters, specify in plain text: Y17: .....	Y17	✓	
<b>Setting of pressure indicator in pressure units</b> Specify in plain text (standard setting: bar): Y21: mbar, bar, kPa, MPa, psi, ... Note: The following pressure units can be selected: bar, mbar, mm H <sub>2</sub> O <sup>1)</sup> , inH <sub>2</sub> O <sup>1)</sup> , ftH <sub>2</sub> O <sup>1)</sup> , mmHG, inHG, psi, Pa, kPa, MPa, g/cm <sup>2</sup> , kg/cm <sup>2</sup> , Torr, ATM or % <sup>1)</sup> ref. temperature 20 °C	Y21	✓	✓
<b>Setting of pressure indicator in non-pressure units <sup>2)</sup></b> Specify in plain text: Y22: ..... up to ..... l/min, m <sup>3</sup> /h, m, USgpm, ... (specification of measuring range in pressure units "Y01" is essential, unit with max. 5 characters)	Y22 <sup>1)</sup> + Y01	✓	
<b>Preset bus address</b> possible between 1 and 126 Specify in plain text Y25: .....	Y25		✓
Only "Y01", "Y21", "Y22", "Y25" and "D05" can be factory preset ✓ = available			
<sup>1)</sup> Not in conjunction with over-filling safety device for flammable and non-flammable liquids (Order Code "E08")			
<sup>2)</sup> Preset values can only be changed over SIMATIC PDM.			

# Pressure Measurement

## Transmitters for general requirements

**SITRANS P DS III**  
**for level**

Selection and Ordering data		Order No.	Selection and Ordering data				Order code			
<b>Mounting flange</b>		D) 7 MF 4 9 1 2	<b>Further designs</b>				<b>HART PA FF</b>			
Directly mounted on the SITRANS P pressure transmitter (converter part) for level, for DS III series		3	Add "-Z" to Order No. and specify Order Code.							
<b>Connection to EN 1092-1</b>			<b>Spark arrester</b>				<b>A01</b>			
<b>Nominal diameter</b>	<b>Nominal pressure</b>		For mounting on zone 0 (including documentation)				✓			
DN 80	PN 40	D	<b>Certificate to EN 10204-2.2</b>				<b>C10</b>			
DN 100	PN 16	G	For certification of oil - and grease-free cleaned and packed version for oxygen and summer applications in which only inert filling liquid may be used. (Only in conjunction with halocarbon oil fill fluid)							
	PN 40	H	<b>Quality inspection certificate (factory calibration) to IEC 60770-2</b>				<b>C11</b>			
<b>Connection to ASME B16.5</b>			<b>Inspection certificate</b>				<b>C12</b>			
<b>Nominal diameter</b>	<b>Nominal pressure</b>		Acc. to EN 10204-3.1				✓			
3 inch	Class 150	Q	<b>Vacuum-proof design</b>				<b>V04</b>			
	Class 300	R	(for use in low-pressure range)				✓			
4 inch	Class 150	T	Note:				suffix "Y01" required with pressure transmitter!			
	Class 300	U	✓ = available							
Other version, add Order Code and plain text: Nominal diameter: ...; Nominal press.: ...		Z	J 1 Y							
<b>Wetted parts materials</b>										
<ul style="list-style-type: none"> <li>Stainless steel 316L               <ul style="list-style-type: none"> <li>- Coated with PFA</li> <li>- Coated with PTFE</li> </ul> </li> <li>Coated with ECTFE<sup>1)</sup></li> <li>Monel 400, mat. no. 2.4360</li> <li>Hastelloy B2, mat. no. 2.4617</li> <li>Hastelloy C276, mat. no. 2.4819</li> <li>Hastelloy C4, mat. no. 2.4610</li> <li>Tantalum</li> </ul>		A								
Other version, add Order Code and plain text: material of parts in contact with the medium: ... Sealing face, see "Technical specifications"		D								
		E								
		F								
		G								
		H								
		J								
		U								
		K								
		Z								
			K 1 Y							
<b>Tube length</b>										
<ul style="list-style-type: none"> <li>None</li> <li>50 mm (1.97 inch)</li> <li>100 mm (3.94 inch)</li> <li>150 mm (5.90 inch)</li> <li>200 mm (7.87 inch)</li> </ul>		0								
Other version: add Order Code and plain text: tube length: ...		1								
		2								
		3								
		4								
		9					L 1 Y			
<b>Filling liquid</b>										
<ul style="list-style-type: none"> <li>Silicone oil M5</li> <li>Silicone oil M50</li> <li>High-temperature oil</li> <li>Halocarbon oil (for O<sub>2</sub>-measurement)</li> <li>Glycerin/water<sup>2)</sup></li> <li>Food oil (FDA-listed)</li> </ul>		1								
Other version, add Order Code and plain text: filling liquid: ...		2								
		3								
		4								
		6								
		7								
		9					M 1 Y			

1) For vacuum on request

2) Not suitable for use in low-pressure range

D) Subject to export regulations AL:N, ECCN:EAR99H

# Pressure Measurement

## Transmitters for general requirements

SITRANS P DS III  
for level

### Dimensional drawings

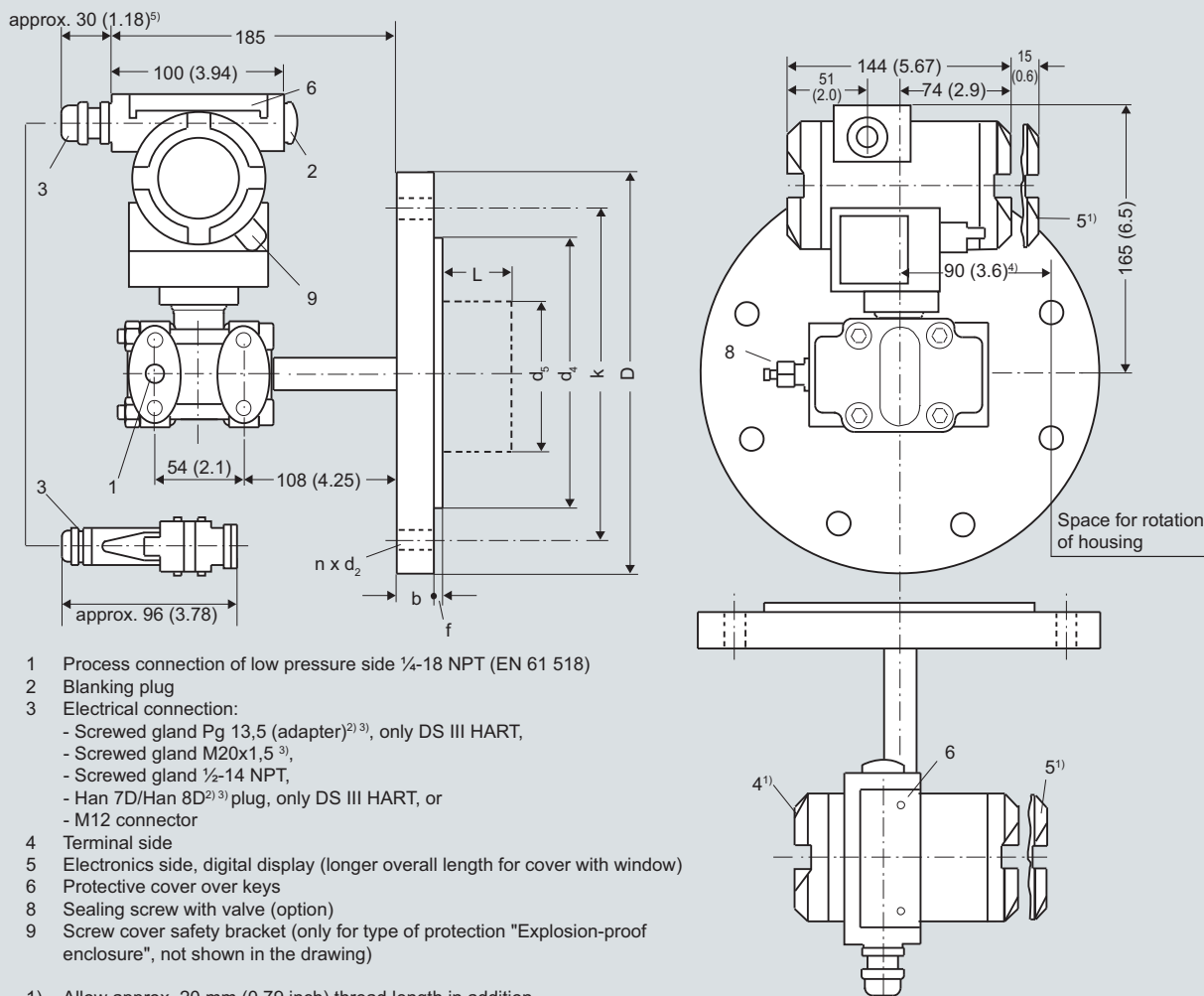

- 1 Process connection of low pressure side 1/4-18 NPT (EN 61 518)
- 2 Blanking plug
- 3 Electrical connection:
  - Screwed gland Pg 13,5 (adapter)<sup>2)3)</sup>, only DS III HART,
  - Screwed gland M20x1,5<sup>3)</sup>,
  - Screwed gland 1/2-14 NPT,
  - Han 7D/Han 8D<sup>2)3)</sup> plug, only DS III HART, or
  - M12 connector
- 4 Terminal side
- 5 Electronics side, digital display (longer overall length for cover with window)
- 6 Protective cover over keys
- 8 Sealing screw with valve (option)
- 9 Screw cover safety bracket (only for type of protection "Explosion-proof enclosure", not shown in the drawing)

- 1) Allow approx. 20 mm (0.79 inch) thread length in addition
- 2) Not with type of protection "Explosion-proof enclosure"
- 3) Not with type of protection "FM + CSA [is + xp]"
- 4) 92 mm (3.62 inch) for minimum distance to permit rotation without indicator
- 5) Approx. 45 mm (1.77 inch) for Pg 13.5 with adapter

SITRANS P DS III HART pressure transmitters for level, including mounting flange, dimensions in mm (inch)

#### Connection to EN 1092-1

Nominal diameter	Nominal pressure	L	D	h	d <sub>2</sub>	d <sub>4</sub>	d <sub>5</sub>	d <sub>M</sub>	j	k	n	L
		mm	mm	mm	mm	mm	mm	mm	mm	mm	mm	mm
DN 80	PN 40	24	200	90	18	138	76	72 <sup>1)</sup>	2	160	8	0, 50, 100,
DN 100	PN 40	20	220	115	18	158	94	89	2	180	8	150 or 200
	PN 40	24	235	115	22	162	94	89	2	190	8	

#### Connection to ASME B16.5

Nominal diameter	Nominal pressure	L	D	d <sub>2</sub>	d <sub>4</sub>	d <sub>5</sub>	d <sub>M</sub>	j	k	n	L
		mm (inch)	mm (inch)	mm (inch)	mm (inch)	mm (inch)	mm (inch)	mm (inch)	mm (inch)	mm (inch)	mm (inch)
3 inch	150	0.94 (24.3)	7.5 (190)	0.75 (19.0)	5 (127)	3 (76)	2.81 <sup>1)</sup> (72)	0.06 (2)	6 (152,4)	4	0, 2, 3.94,
	300	1.12 (29)	8.25 (210)	0.87 (22.2)	5 (127)	3 (76)	2.81 <sup>1)</sup> (72)	0.06 (2)	6.69 (168,3)	8	5.94 or 7.87
4 inch	150	0.94 (24.3)	9 (230)	0.75 (19.0)	6.19 (157.2)	3.69 (94)	3.5 (89)	0.06 (2)	7.5 (190,5)	8	(0, 50, 100,
	300	1.25 (32.2)	10 (255)	0.87 (22.2)	6.19 (157.2)	3.69 (94)	3.5 (89)	0.06 (2)	7.88 (200)	8	150 or 200)

d: Internal diameter of gasket to DIN 2690

d<sub>M</sub>: Effective diaphragm diameter

<sup>1)</sup> 89 mm = 3 1/2 inch with tube length L=0.